

User Manual

Bitpod

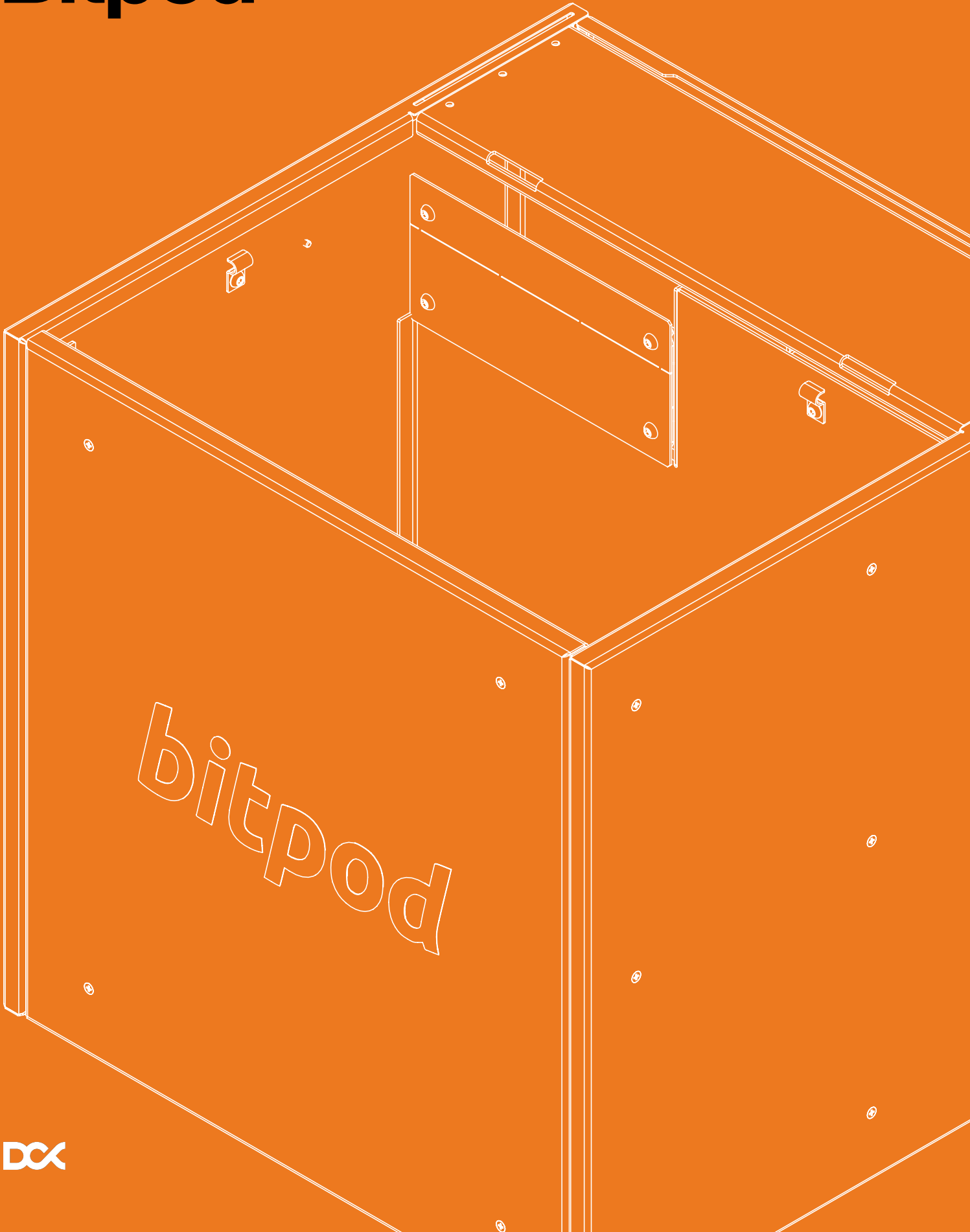

Table of Contents

1. SAFETY AND WARNINGS.....	4
1.1. HEALTH AND SAFETY GUIDELINES	5
2. PACKAGE CONTENTS	6
3. PREREQUISITES	8
3.1. INSTALLATION LOCATION FOR BITPOD.....	9
3.2. INSTALLATION LOCATION FOR DRY COOLER ICP15.....	9
3.3. POWER SUPPLY	10
3.4. REQUIRED FLUIDS	10
3.5. TOOLS	11
4. INSTALLATION.....	12
4.1. MOUNTING.....	13
4.2. HYDRAULIC CONNECTION	16
4.3. FILLING THE SYSTEM.....	19
4.4. FILLING THE SECOND CIRCUIT.....	22
4.5. ELECTRICAL CONNECTION.....	26
4.6. SENSORS AND DISPLAY.....	27
5. OPERATION.....	28
5.1. TURNING THE BITPOD ON AND OFF	29
5.3. BITPOD.....	29
5.4. FAN CONTROLLER.....	29
5.2. TURNING THE DRY COOLER ON AND OFF	29
5.5. RESET TO FACTORY SETTINGS	30
5.6. MONITORING.....	31
6. MAINTENANCE	34
6.1. REGULAR INSPECTIONS.....	35
6.2. CLEANING.....	35
6.3. COOLANT MAINTENANCE	35
7. TROUBLESHOOTING.....	36
7.1. ERROR E1/E- ON THE DRY COOLER PUMP	37
7.2. PUMP IN THE ENCLOSURE IS OVERHEATING.....	37
8. FAQ.....	38

1. Safety and Warnings

1.1. HEALTH AND SAFETY GUIDELINES

Before beginning installation and operation, please review and adhere to the following safety guidelines to avoid injury or damage to equipment.



Personal Protective Equipment (PPE): Always use appropriate PPE, including gloves (nitrile gloves recommended) and safety glasses.



Heat Reuse System: If you are considering creating a heat reuse system, contact us at support@dcx.eu for guidance.



Noise emission: Hearing protection is recommended if working close by for long periods.



Eye Protection: Prevent installation liquids from coming into contact with your eyes. In case of contact, rinse thoroughly and seek medical attention.



Assistance Recommended: We strongly recommend having a second person assist with installation and lifting of the device to prevent injury.



Power Disconnection: Ensure the device is completely disconnected from the power supply before starting any installation or maintenance work.



Children's Safety: Keep the appliance out of reach of children. Children should never play with or operate this device. To avoid injury, do not insert fingers or objects into the air inlet or outlet grilles.



Burn Hazard: Certain components can become very hot during operation. Avoid contact with:

- Pump on the enclosure
- Pipes
- Liquid coolant inside the enclosure



Device Modification: Any modifications to the device without manufacturer approval may void the warranty and could result in serious malfunction or injury.



Electrical Modifications: If the plug requires changing, consult a qualified electrician. Do not attempt electrical modifications unless professionally certified.



Power Cord Safety: Only use power cords in good condition. Do not use defective or damaged cords.



Prohibited Consumption: Do not ingest any liquids intended for installation purposes. These liquids are not safe for consumption.



Water Exposure Warning: Do not allow water to come into contact with any electrical components of the machine, as this may cause a short circuit.



Rear Surface Safety: Do not touch or slide your hand across the rear side of the Dry Cooler. This area contains sharp metal fins and edges that can cause cuts, punctures, or other injuries to fingers or hands.



Coolant Contamination Warning: Never allow water to mix with the liquid coolant. Mixing may result in coolant contamination and damage to the device.



Fan Grille Safety: Do not insert fingers or other objects into the fan grille to prevent injury.



Ventilation Requirement: Do not block or obstruct any vents for proper airflow.

WARNING

Failure to follow these guidelines may result in serious injury, equipment damage, or loss of warranty coverage. DCX shall not be held liable for any safety incidents, injuries, or damages resulting from improper operation or use of DCX equipment in unsuitable environmental conditions. Always read the full installation and user manual carefully before proceeding. Any non-compliance with these instructions may void the warranty. If you are considering any modifications or alterations to the device, we strongly recommend contacting our support team in advance to confirm whether such changes are permissible.

2. Package Contents

1

Bitpod



2

Dry Cooler ICP15



3

User Manual

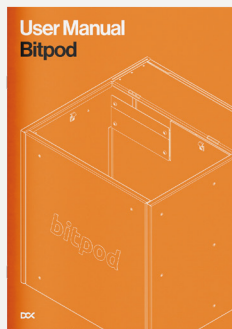

4

Dielectric Fluid (ThermaSafe)



5

Mounting Accessories



Clamps (4 pcs)



1" hoses (2 pcs)

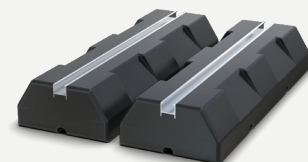

Anti-vibration bases (2 pcs)



Orange hand pump (1 pcs)



Mounting brackets with complete set of screws (2 pcs)

3. Prerequisites

3.1. INSTALLATION LOCATION FOR BITPOD

Ensure a well-ventilated, dry, and contaminant-free area. The device should be placed on a flat, stable surface.

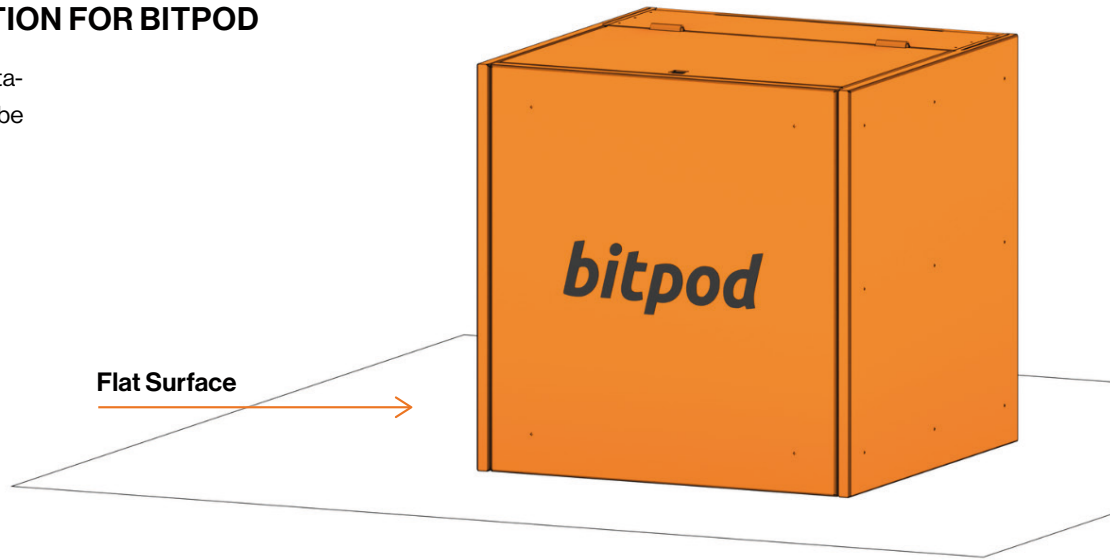

3.2. INSTALLATION LOCATION FOR DRY COOLER ICP15

- Place the Dry Cooler on a flat, stable surface outdoors with access to fresh air, ideally on the north side of the building.
- Maintain a maximum distance of 10 m (32') between the Dry Cooler and the Bitpod. To position the Dry Cooler more than 10 m (32') away, an additional pump is required.
- Maintain a minimum of 20" (50 cm) between the Dry Cooler and the wall. Allow at least 40" (100 cm) of clearance in front of the unit. Allow at least 20" (50 cm) of clearance behind the unit. The provided tubing (20 m roll) enables positioning the ICP15 Dry Cooler up to 10 m (32') from the immersion mining enclosure.

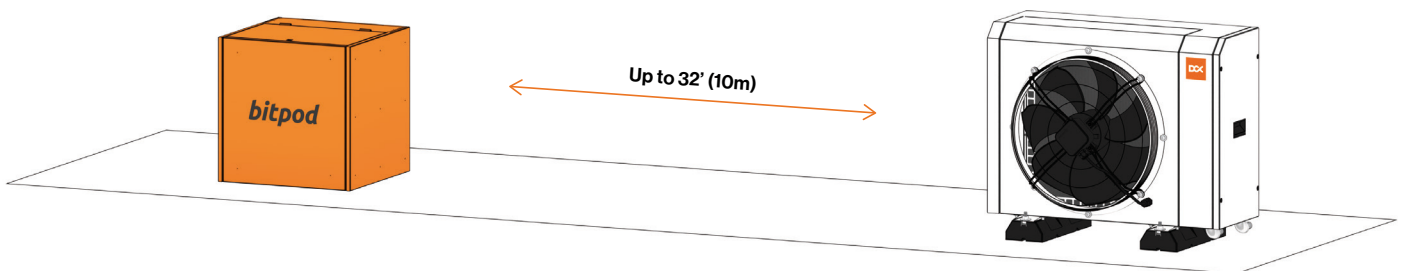
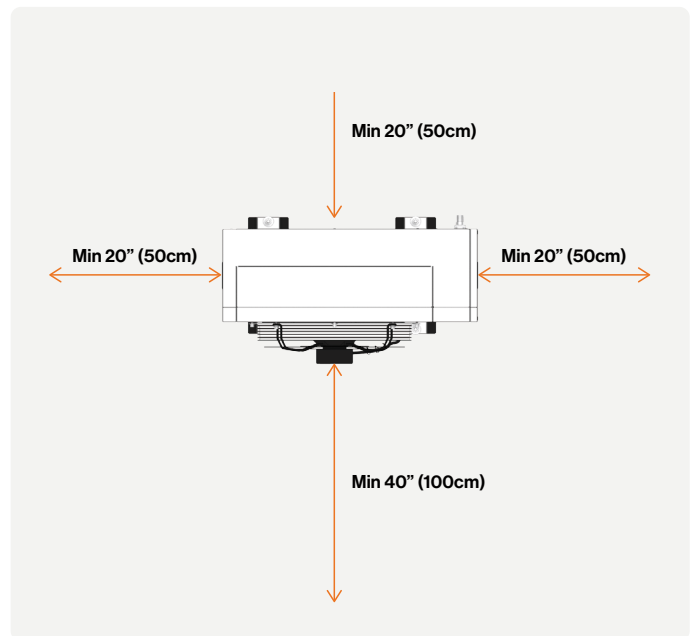

3.3. POWER SUPPLY



Electrical Connection

Connect the Dry Cooler and the enclosure to the power supply. All enclosure components require a single-phase 230V (220-240V range), 50/60Hz power connection.



Important Warning

Do not confuse single-phase 220-240V with American split-phase or dual-phase 240V. The split-phase 240V setup uses two hot legs of 110-120V, resulting in 243-244V, which can damage equipment, including the fan controller and capacitors in the fans.



Voltage Converter Recommendation

To prevent damage, use a voltage converter that converts USA 110V to the required EU/Asia 230V AC. For continuous operation, a converter with at least double the wattage capacity of the connected component (e.g., 2500W) is recommended.



Compatibility Note

The cooling system will not function correctly with split-phase 240V (2 x 120V) or with 208V power. Operating on split-phase 240V may damage fan capacitors or system pumps. To avoid costly repairs, connect a transformer to a 120V power feed and attach the ICP15 and immersion enclosure directly to the transformer. This also adds protection against power surges.

WARNING Incorrect power configuration may damage your system!

3.4. REQUIRED FLUIDS



Demineralized Water

Approximately 15 liters.



Glycol

Necessary if installation is in an area where temperatures fall below 0°C to prevent water from freezing. The amount needed varies with temperature. For guidance on the glycol-to-water ratio, use the calculator at: <https://vapcocompany.com/glycol-calculator/>.

3.5. TOOLS



10 mm open-end or socket wrench
for 1" hose clamps

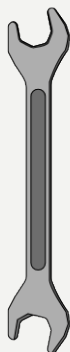

17 mm open-end wrench
for DC legs

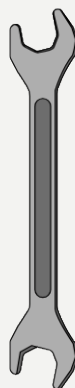

22 mm open-end wrench
for connecting the hand pump to the check valve
(for 1/2" nipple)



26 mm open-end wrench
for connecting the hand pump to the nipple



5 mm Allen key
for DC plates

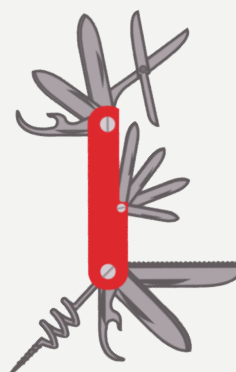

Knife or scissors
for cutting 1" rubber hose

4. Installation

4.1. MOUNTING

STEP 1

Place the device in the designated location. Ensure the distance between the Bitpod and the Dry Cooler is less than 10 meters. (You have a 20-meter hose; dividing it in half provides two 10-meter hoses.) The height difference must not exceed 6 meters. If it does, an additional pump is required.

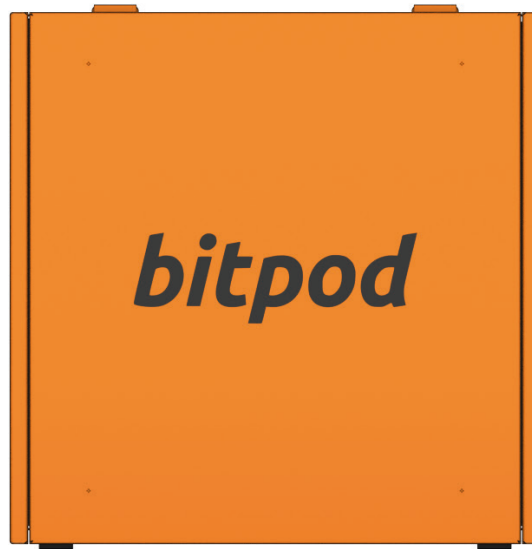

Max 6m

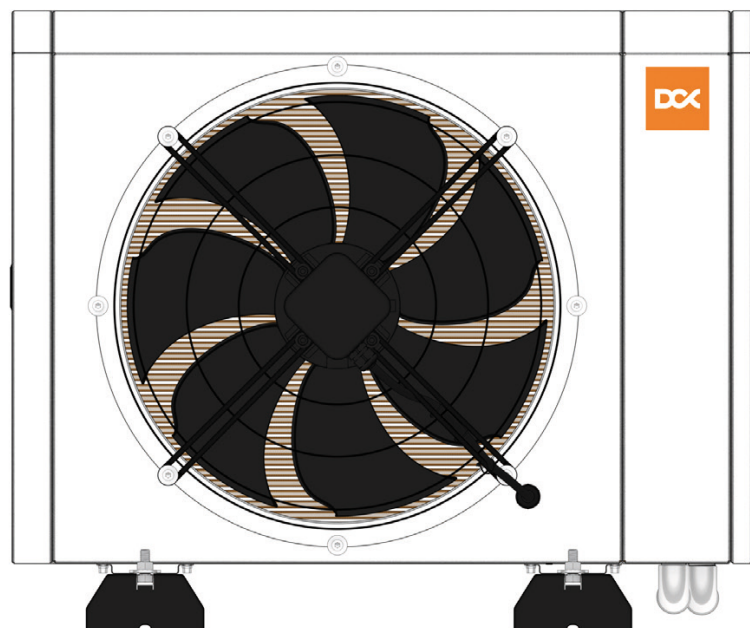

STEP 2

Secure the device using the provided accessories.

Bitpod: Place the device indoors on a flat, stable surface.

Dry Cooler: Follow the instructions below to assemble the anti-vibration bases:

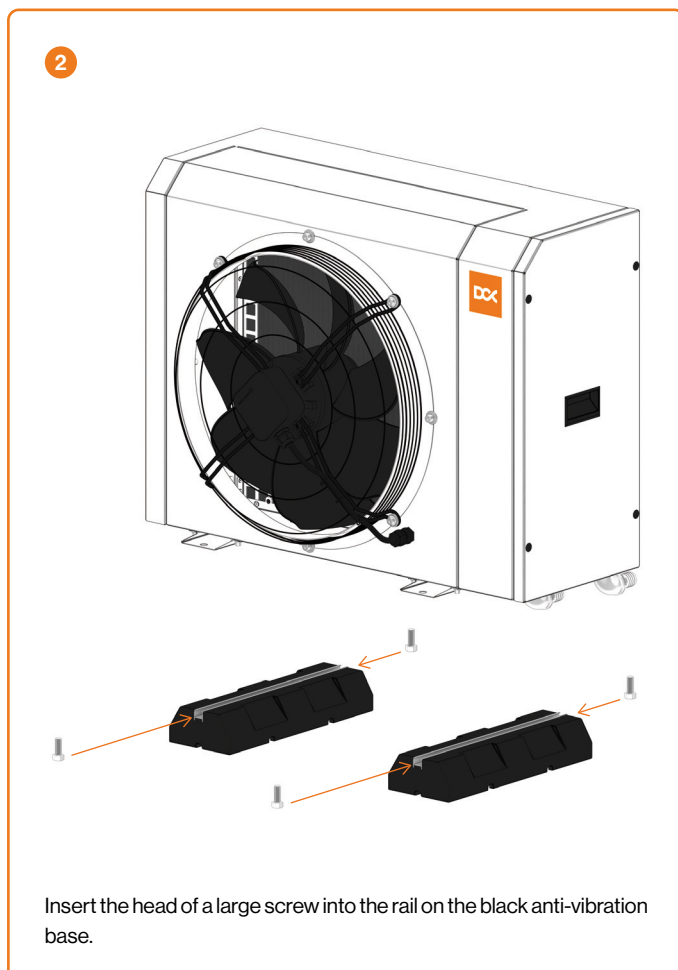
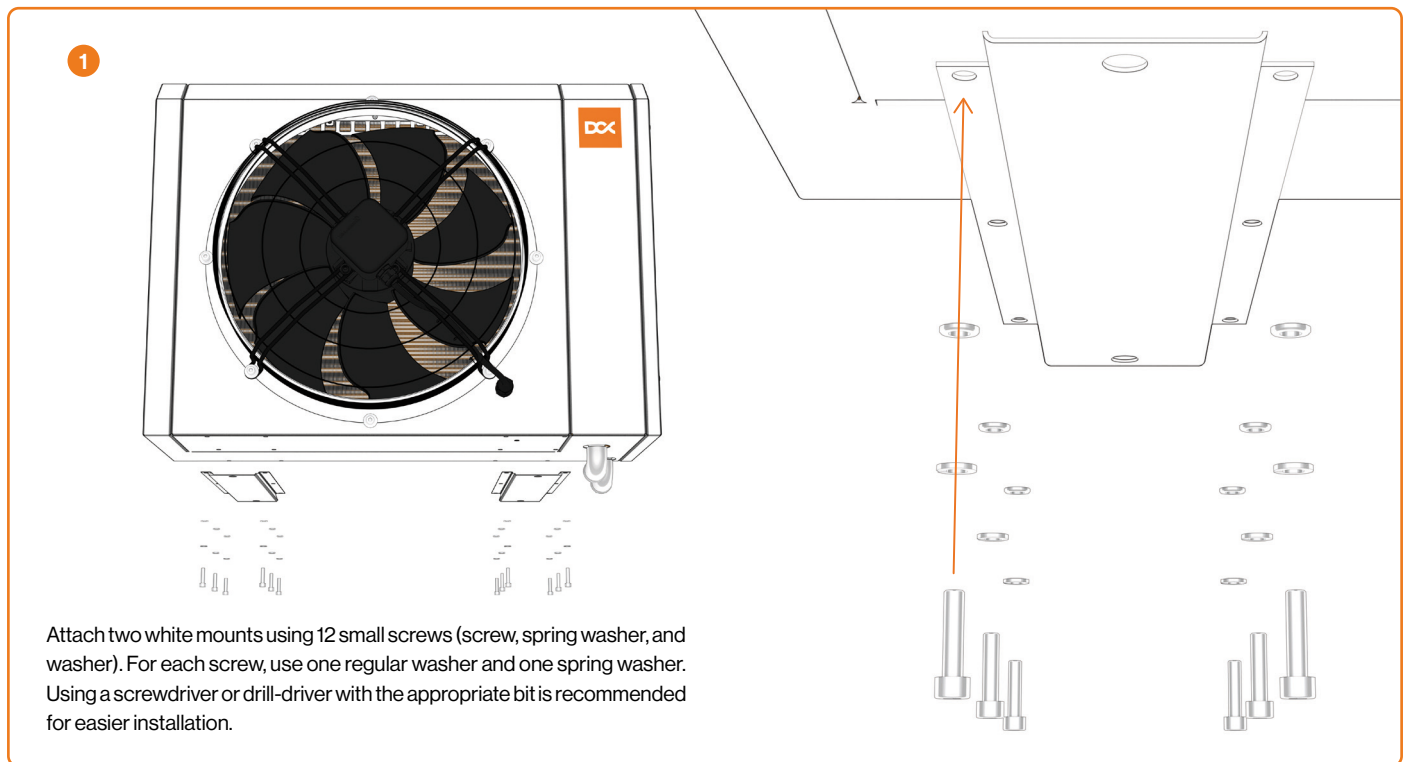

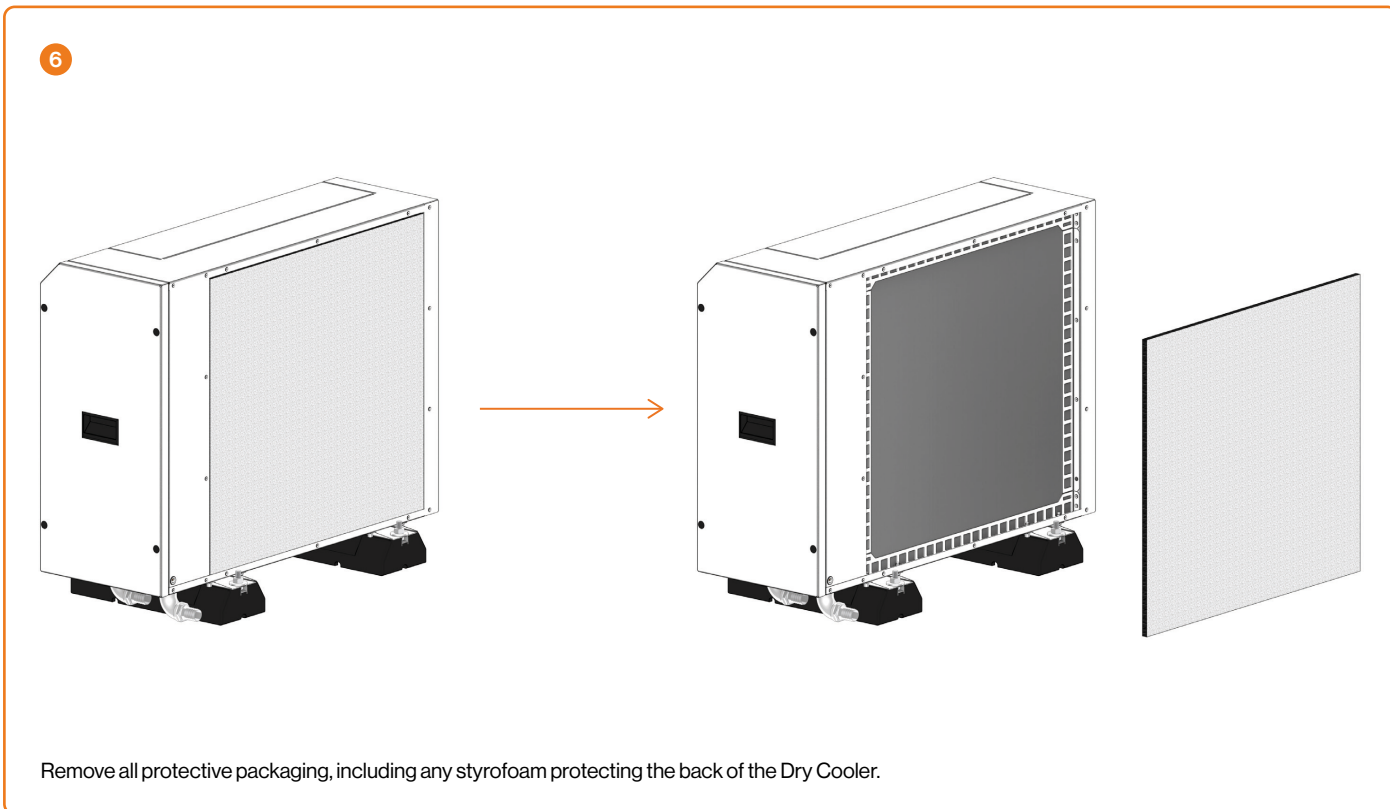
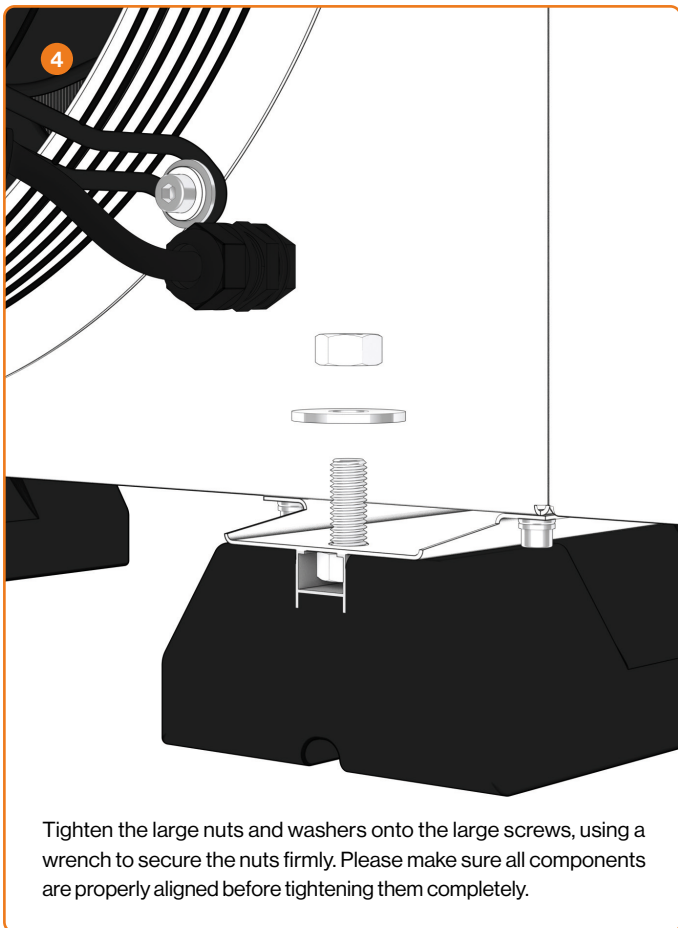

INFO

You can also watch the video titled „How to Install Dry Cooler Legs” for a visual, step-by-step guide:
<https://youtu.be/wzAf5DT22j4?feature=shared>

4.2. HYDRAULIC CONNECTION

STEP 1

Identify the type of heat exchanger installed in your Bitpod unit. There are two types of heat exchangers available:

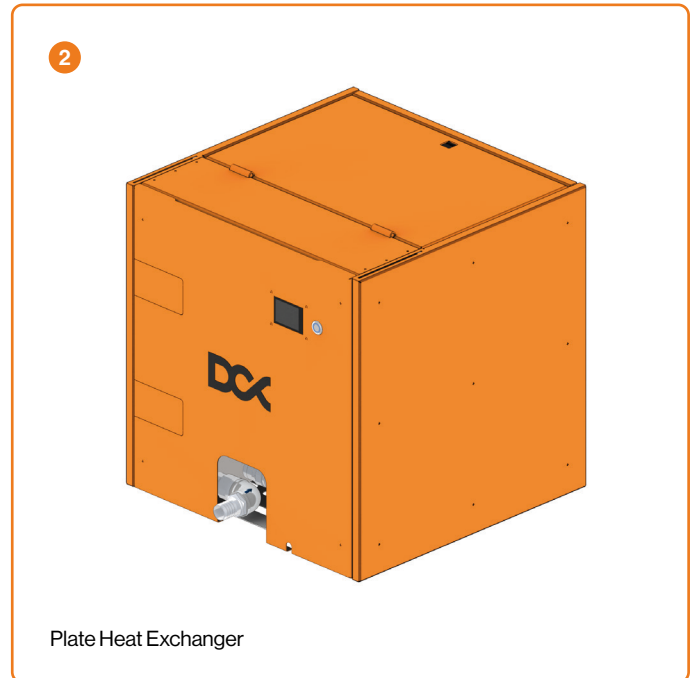
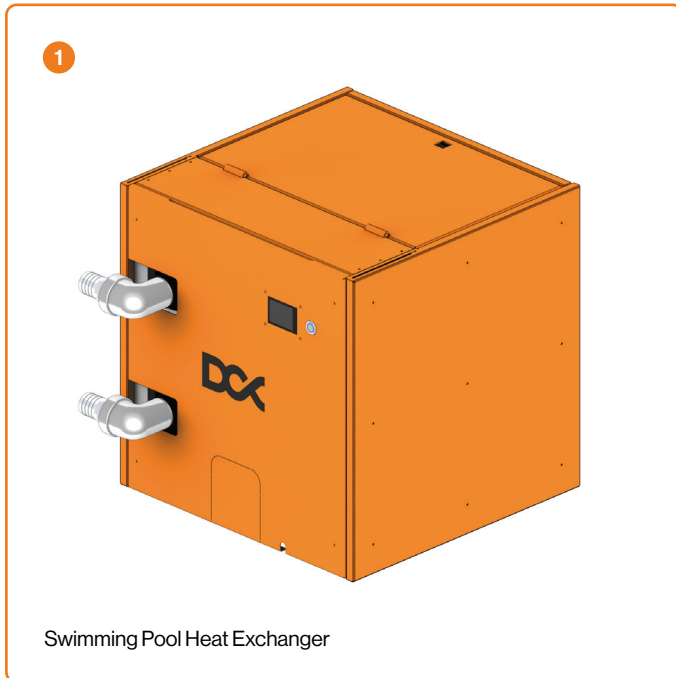

STEP 2

To access the internal hydraulic components, remove the rear cover of the device. Make sure the unit is placed on a flat, stable surface. Using a suitable screwdriver or power driver, unscrew all the fasteners that hold the rear panel

in place. Grip the panel firmly by its edges and carefully pull it backward to detach it from the enclosure. Proceed with caution to avoid damaging any internal components during the removal process.

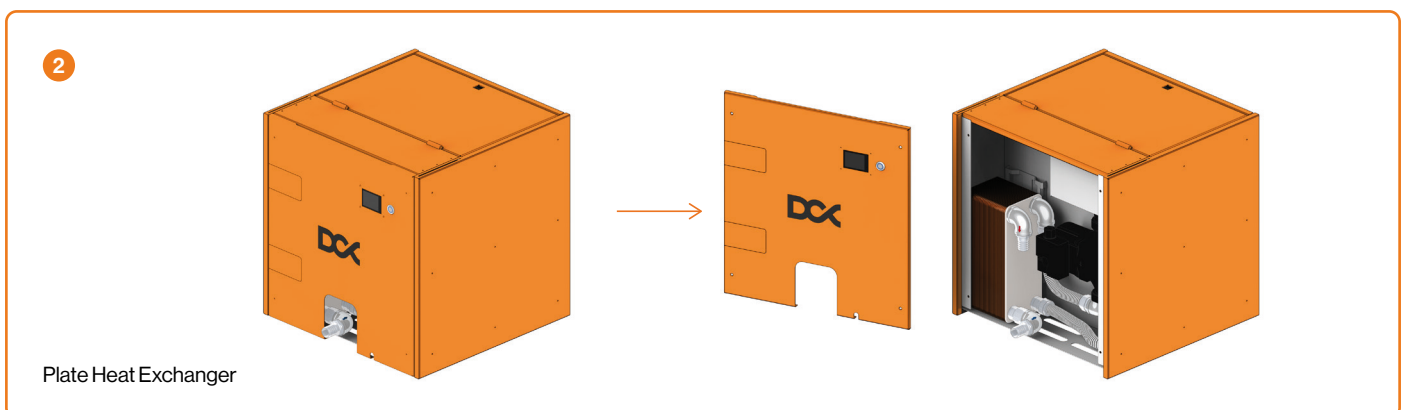
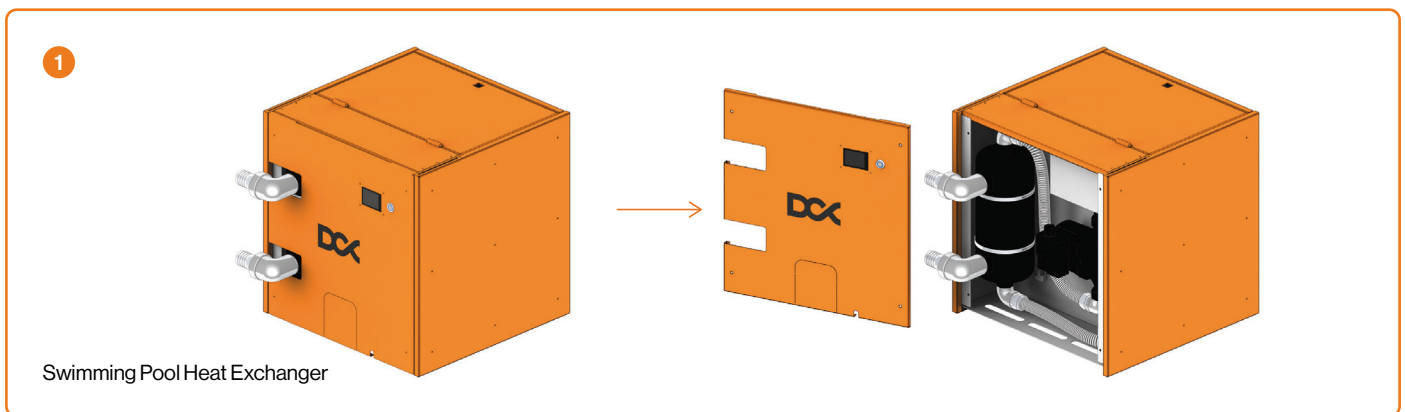

STEP 3

Swimming Pool Heat Exchanger: Connect the device to the pool circulation system and the pump using the side ports located on the side wall of the unit. The upper port is for hot water out (return to the pool). The lower port is for cold water in (from the pool pump). You can ignore the Dry Cooler circuit connections, as they are not needed in this configuration.

Plate heat exchanger: Connect the hoses to the device according to the color-coded arrows on the elbows (blue to blue, red to red). Ensure the hose clamps are tightened firmly, securing the hose as close to the elbow as possible to prevent it from loosening under pressure.

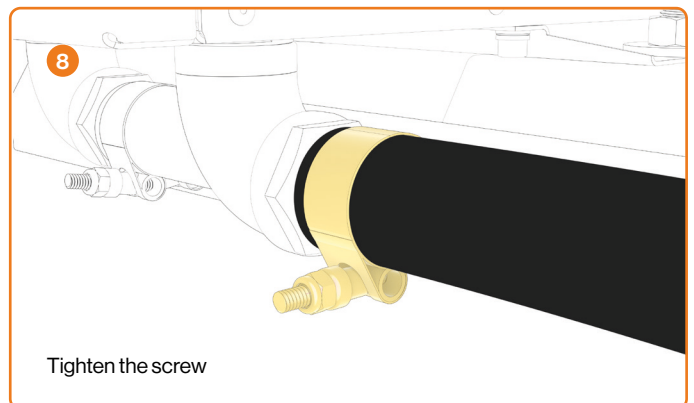
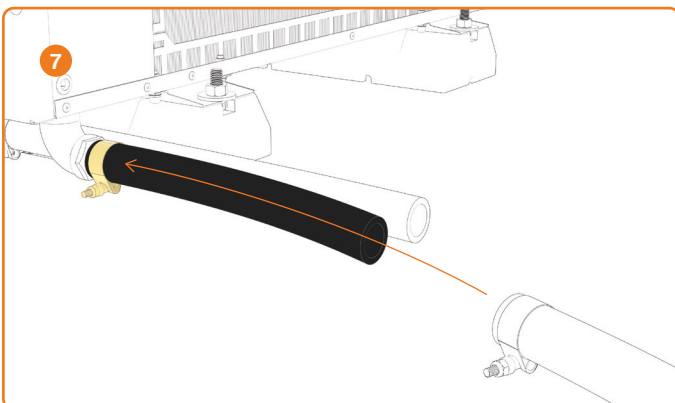
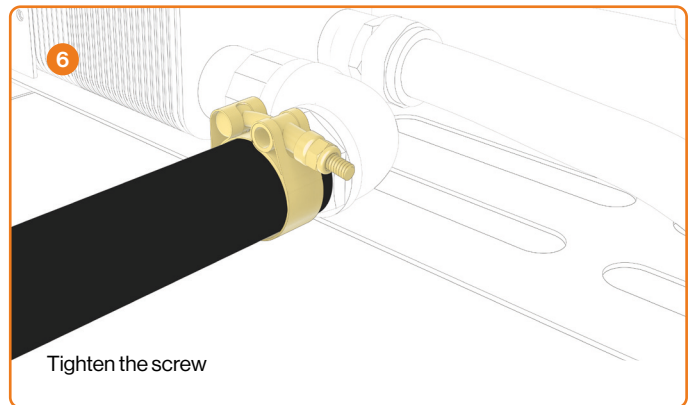
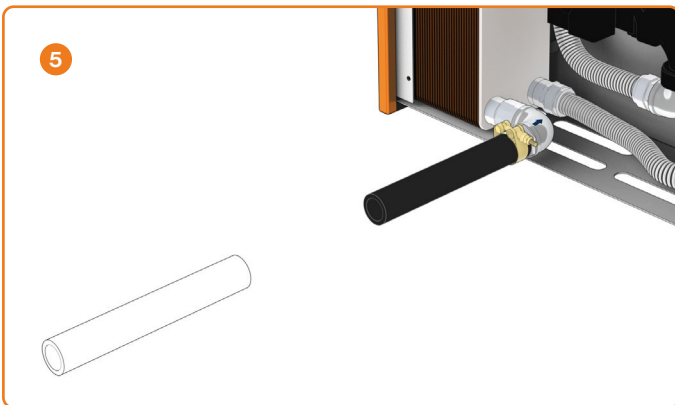
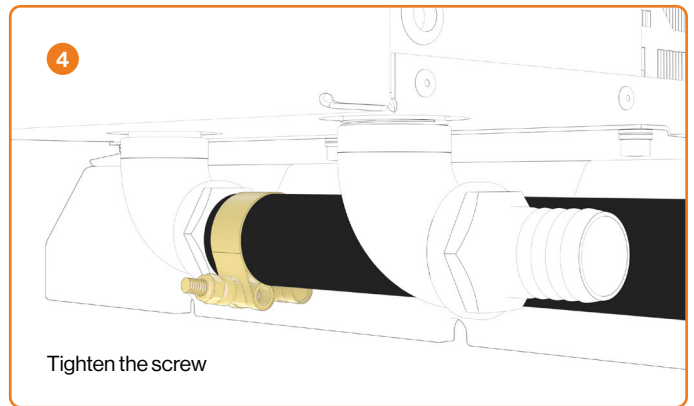
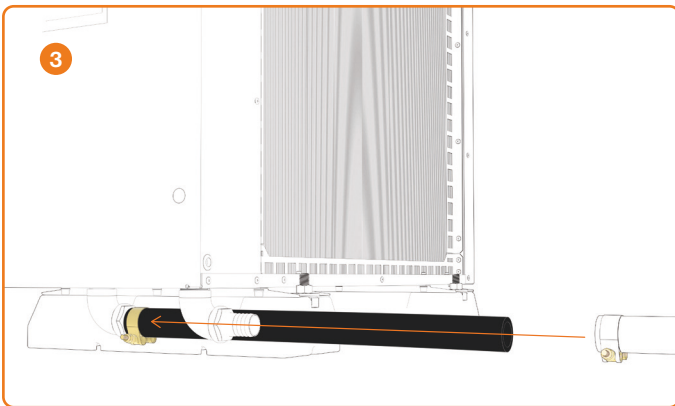
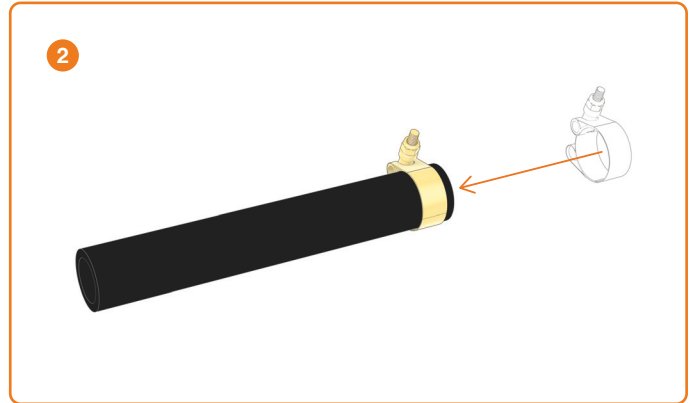

STEP 4

To secure the hose connections, position the hose clamps about 5 – 10 mm from the end of each hose, ensuring they are placed over the metal fittings. Use an appropriate wrench to tighten the clamps firmly, preventing any movement or leakage under operating pressure. Make sure that each hose is securely attached and does not shift when gently pulled.

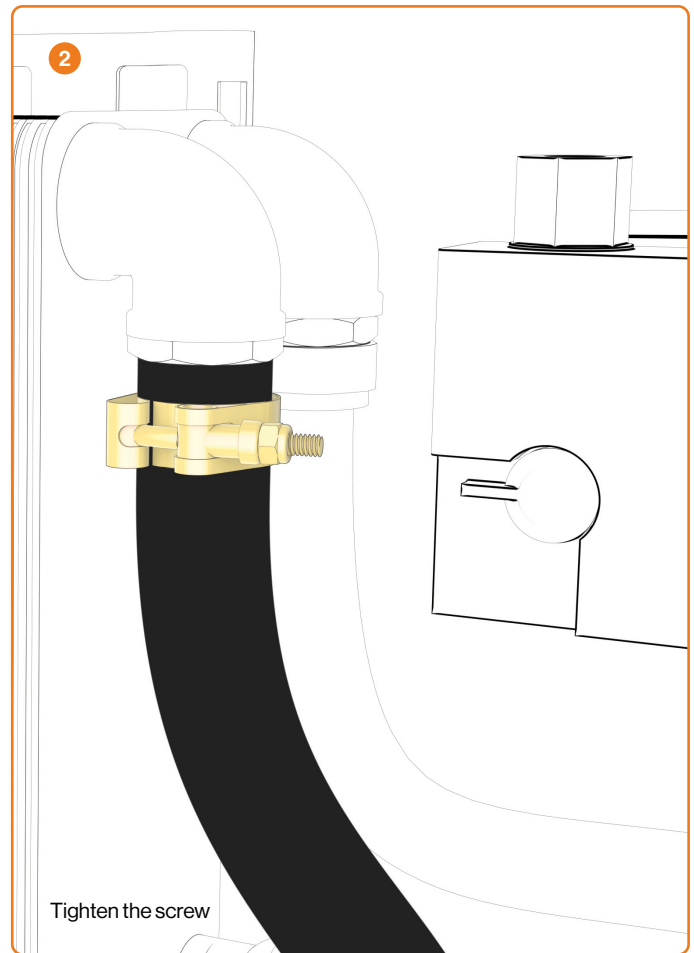
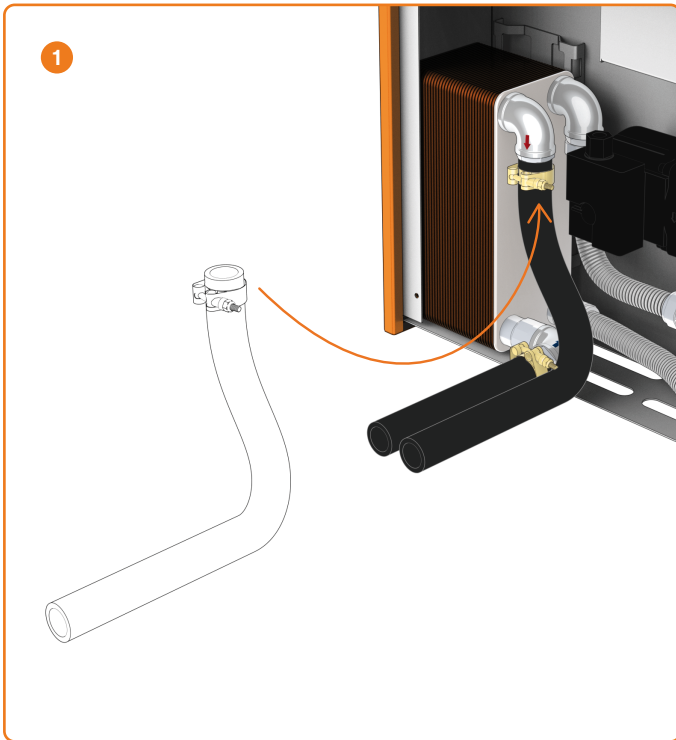

STEP 5

Once all hoses have been connected and secured with hose clamps, perform a visual inspection of each connection point. Ensure that each hose is fully inserted into its corresponding metal fitting and that the clamp is positioned correctly. Verify that all hose clamps are tightly secured using an appropriate wrench. After completing your visual inspection, gently pull each hose near

the connection point to confirm that it is securely attached and does not shift. Check that the routing of the hoses is free from kinks, sharp bends, or contact with sharp edges, and ensure there is sufficient slack to accommodate thermal expansion or vibrations during operation.

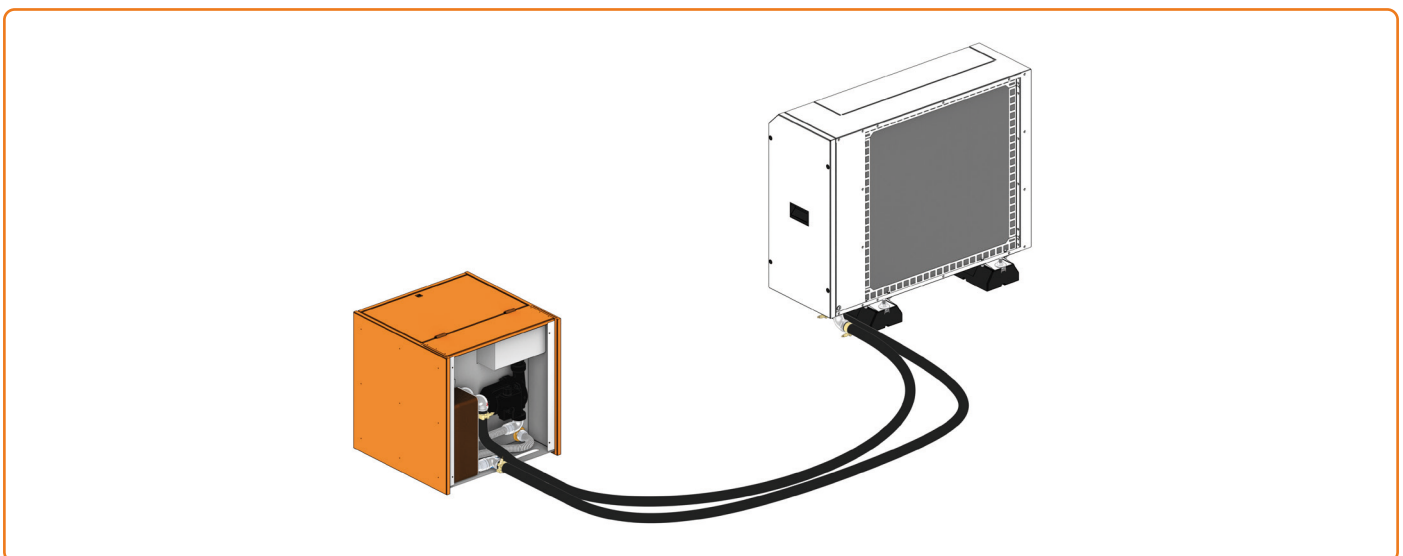

STEP 6

Verify that all connections are tight and secure. This step is essential for ensuring the reliable and leak-free operation of the hydraulic circuit under normal working conditions.

INFO

You can also watch the video for a visual, step-by-step guide:
<https://youtu.be/ovdBCAsdmaU?feature=shared>

4.3. FILLING THE SYSTEM

STEP 1

Use the orange hand pump and demineralized or distilled water to fill the water circuit (loop between the Dry Cooler and the enclosure). Approximately 25 liters of fluid are needed to fill the loop. We recommend having 30–40 liters available to compensate for potential spills or refilling during the process. Additionally, use a glycol mixture that is adjusted to suit your local external temperatures.

As temperatures fluctuate, freezing conditions may require a higher concentration of glycol in the mixture.

Please refer to the mixing ratio calculator located in the Required Fluids section for detailed guidance.

WARNING

Do not use dielectric fluid into the loop between Dry Cooler and enclosure. Dielectric fluid goes only into the enclosure.

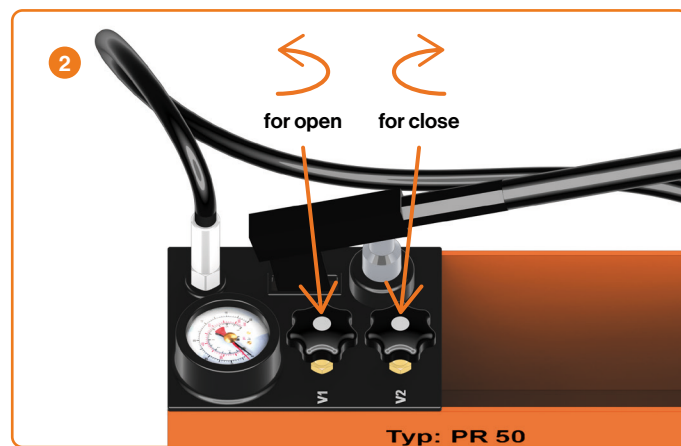
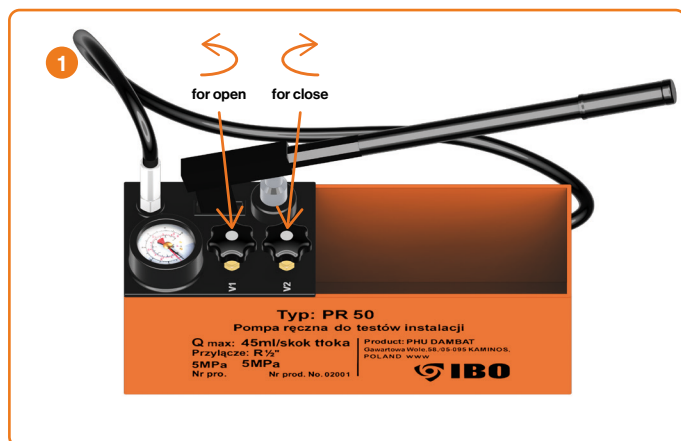

STEP 2

To access the filling point and internal components, remove the Dry Cooler side panel. The illustration above shows the correct positioning.

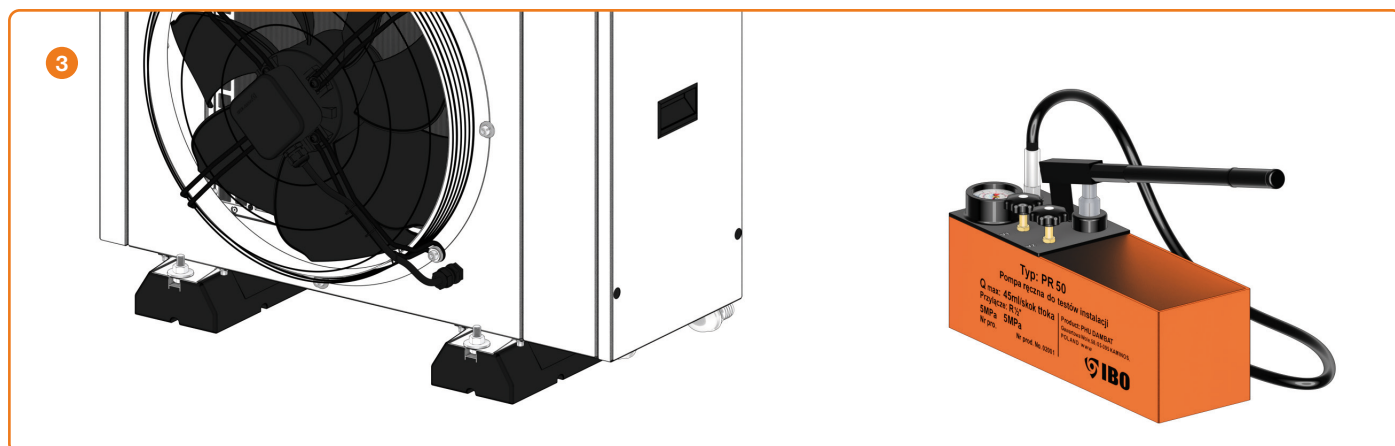
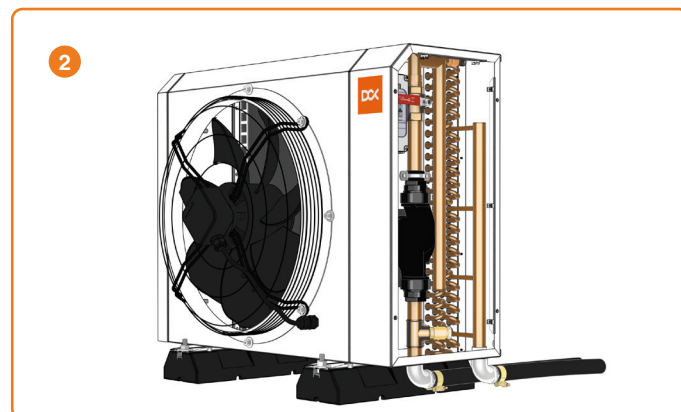
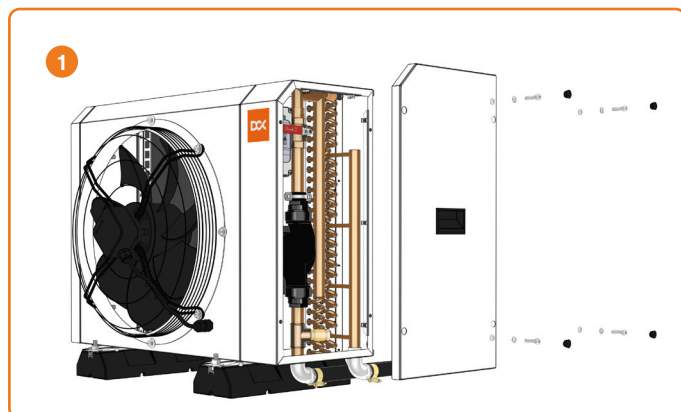

STEP 3

Open all valves in the cooling circuit. It is crucial to ensure that all valves in the system are fully open to allow unrestricted flow and proper air venting during filling. Air venting should be done after filling is complete.

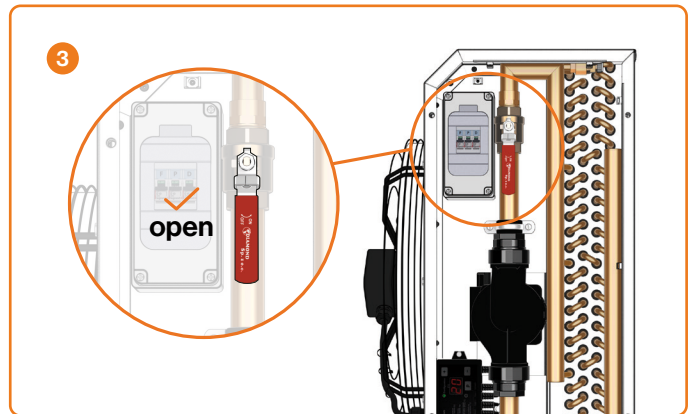
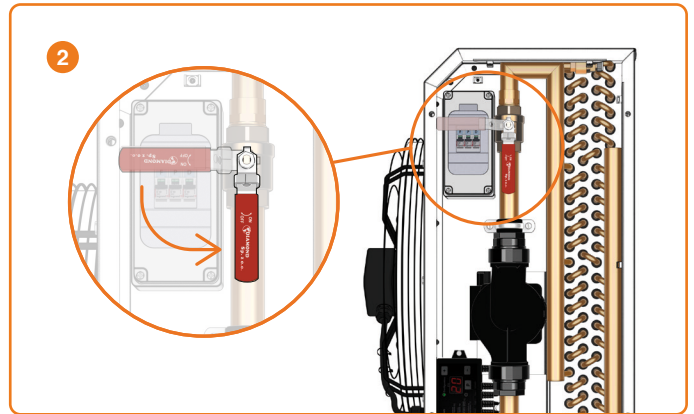
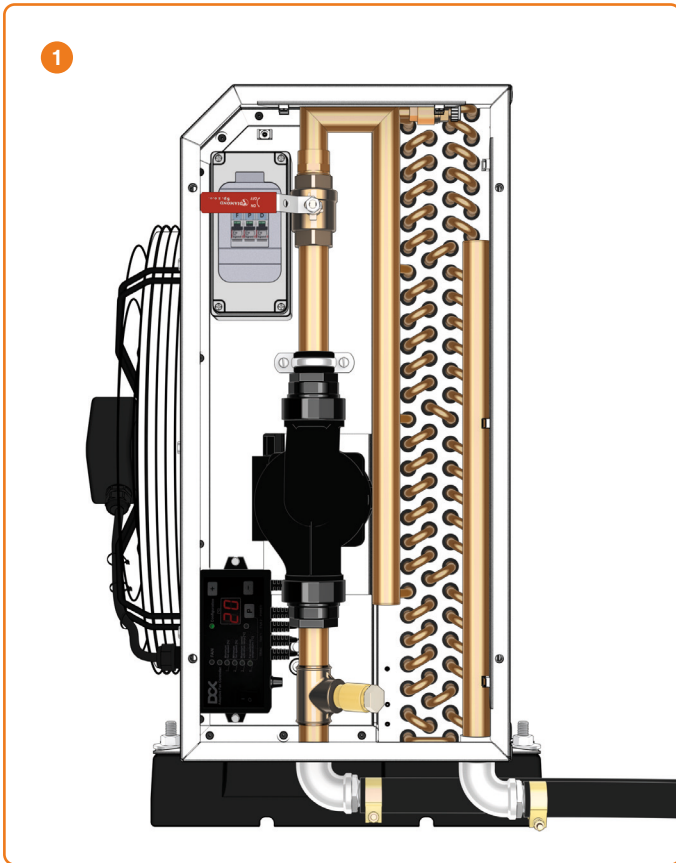

STEP 4

Remove the protective cap from the one-way valve located **below** the black internal pump inside the Dry Cooler. Next, screw the brass nipple at the end of the orange hand pump hose into the now-exposed valve. Ensure it is firmly tightened to avoid any leakage during the filling process.

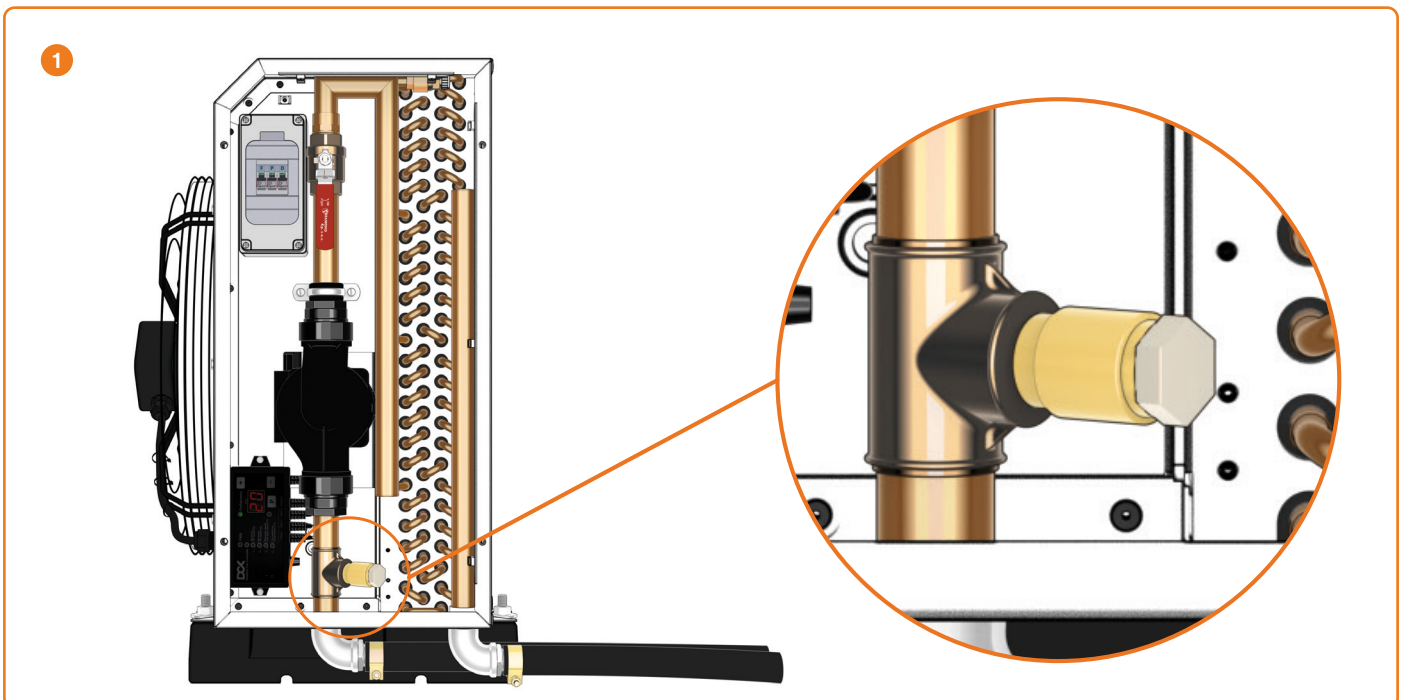

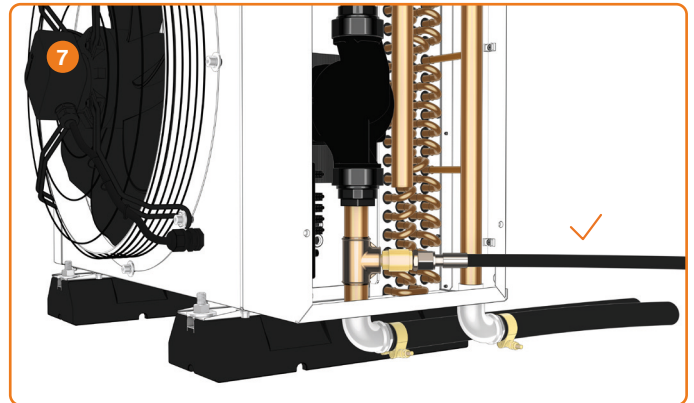
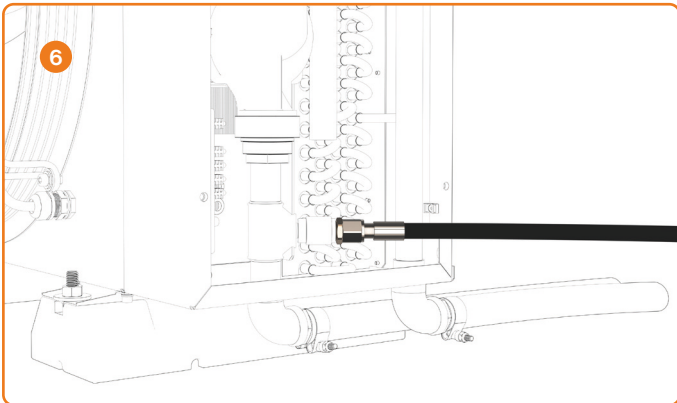
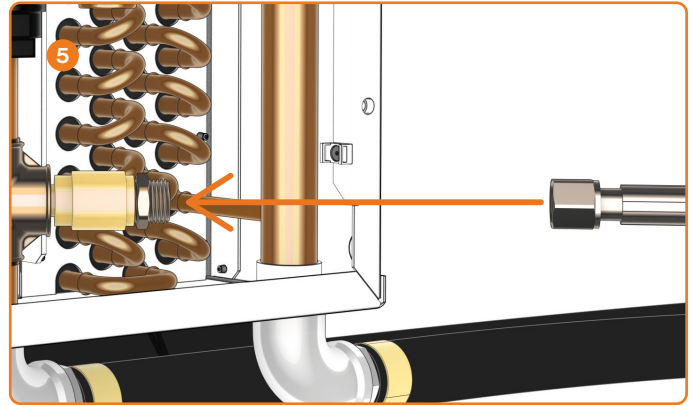
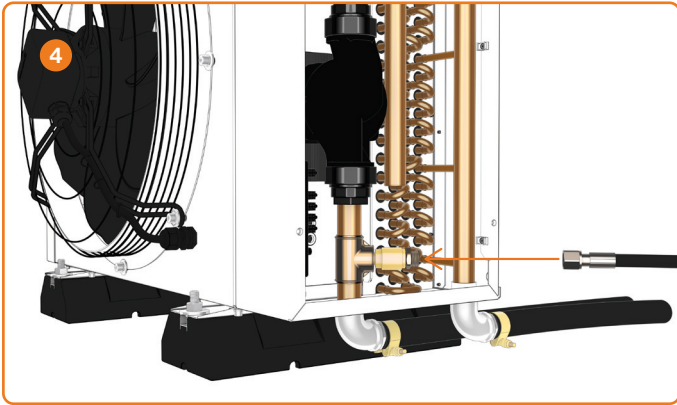
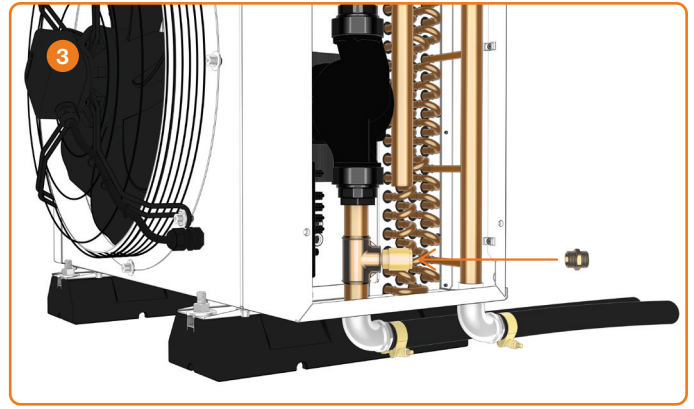
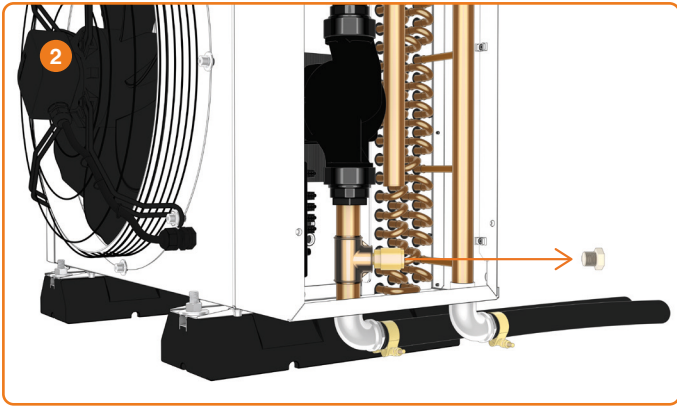

STEP 5

Fill the orange hand pump with either distilled water or a water/glycol mixture. Open the red-handled valve located above the internal pump inside the Dry Cooler to allow fluid flow. On the hand pump, turn valve V1 (located near the pressure gauge) counterclockwise to open it and turn valve V2 clockwise to close it.

Begin pumping the fluid into the circuit. Monitor the pressure on the gauge. Refer to the black outer scale, which indicates pressure in bar (not PSI). Stop pumping once the pressure reaches 2 bar. Do not exceed 2,5 bar! The red marker needle on the gauge shows the maximum peak pressure recorded. After filling, you can reset the needle to zero by rotating it counterclockwise.

WARNING

Do not exceed 2-2,5 bar at any time. The system is designed to operate safely within 2-2,5 bar. Exceeding 4 bar may cause hose fittings to slip, leaks or contamination of the dielectric fluid with water.



STEP 6

Once the circuit is filled and the pressure reaches approximately 2-2,5 bar. **Do not exceed 4 bar** (always monitor the gauge). Release any trapped air using the bleed valve located at the top right of the copper pipe assembly. To do this, slightly open the bleed valve counterclockwise for a brief moment

to allow air to escape. It is normal for a small amount of water to spray out during this process. Repeat the bleeding process several times to ensure all air is removed.

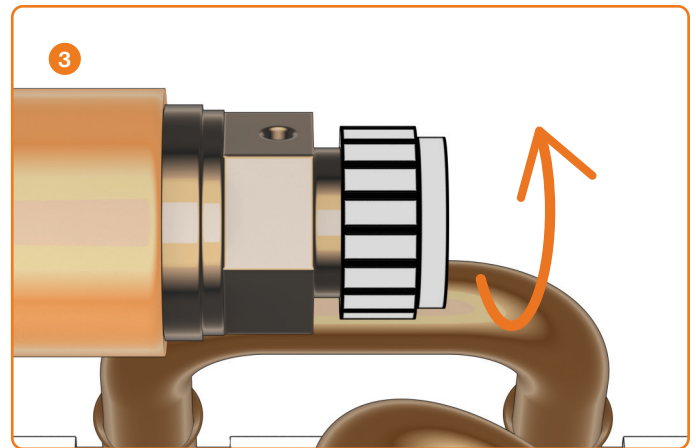
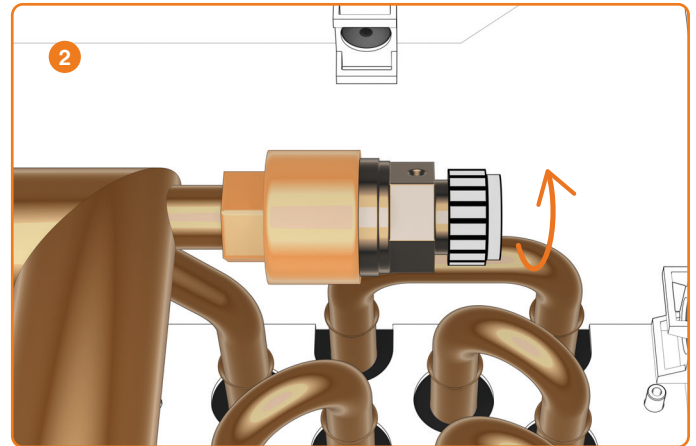
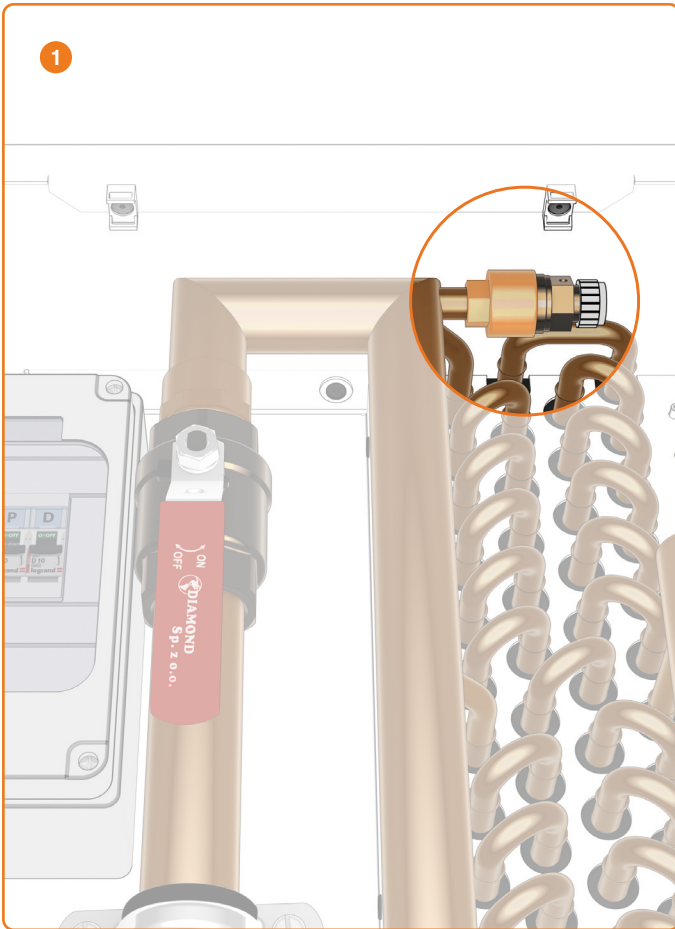

STEP 7

After the initial bleeding, check the system pressure on the gauge and top it up if necessary to maintain approximately 2-2,5 bar. You may add a small amount of additional water during this stage to raise the pressure indicator to approximately 2-2,5 bar. To enhance the removal of air, gently tilt or shake the Dry Cooler to help release any air pockets trapped inside the unit.

Next, turn on the system and activate only the pump (keep the fans turned off). Listen closely to the hydraulic system. The presence of air bubbles may cause irregular flow sounds or bubbling noises from the pump. If you hear such noises, repeat the bleeding process using the top bleed valve until the system operates smoothly and quietly.

WARNING Air may accumulate again after the loop heats up during operation. In this case, perform another round of bleeding to restore proper flow.

4.4. FILLING THE SECOND CIRCUIT

STEP 1

Ensure that the interior of the Bitpod unit is thoroughly cleaned and is free of any foreign objects, dust, or residual materials that could disrupt fluid dynamics or system performance.

STEP 2

Disconnect and remove all fans from the miners, including the fans attached to the power supplies. After physically removing the fans, either install a fan simulator on each fan header or configure the miner using the appropriate software or firmware to switch to Immersion Mode. This step prevents boot errors and ensures proper thermal behavior in a liquid-cooled environment.

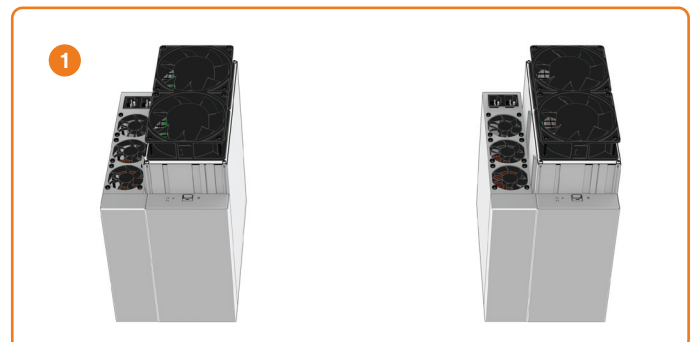

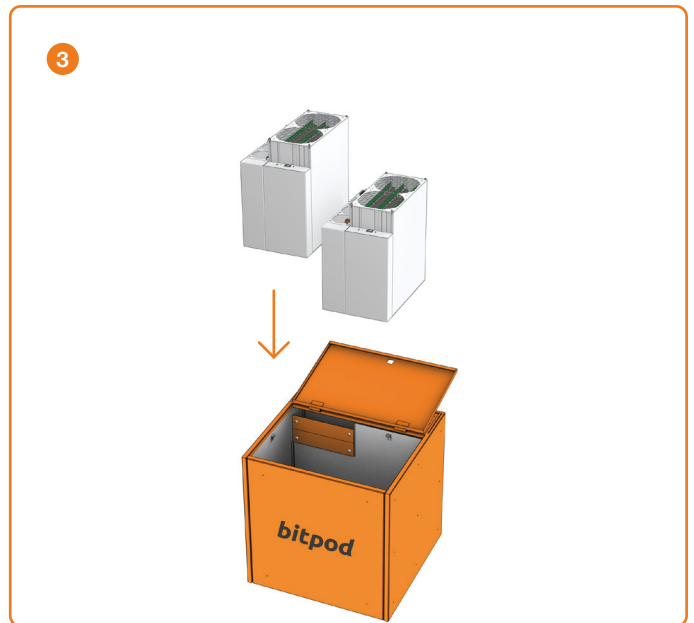
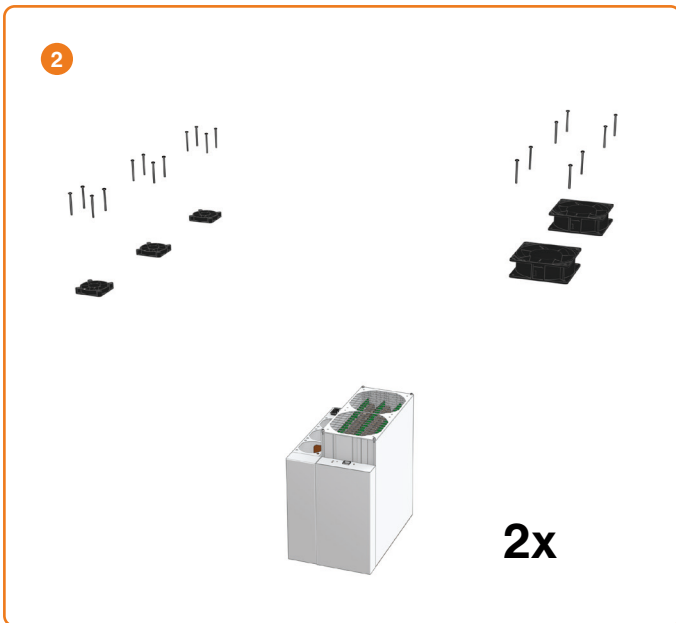

STEP 3

Place the miners into the Bitpod. Ensure that the miners are properly aligned with the internal brackets or supports, and verify that there is no contact with cables or structural elements that could obstruct correct placement or hinder future liquid flow. Avoid tilting the devices during insertion to prevent mechanical stress on the connectors. Each miner must rest flat

on the integrated bottom support edges of the Bitpod (internal rails). These support edges ensure proper clearance, stable positioning, and optimal coolant distribution around the units. Correct placement is critical for effective thermal performance and uniform flow conditions.

WARNING

All miners must be installed directly on the dedicated internal support edges (bottom rails) of the Bitpod. Each unit must be supported on all designated edges (4 support lines), ensuring full contact and stability, with no components suspended or unevenly loaded. Incorrect placement may result in reduced cooling efficiency and improper coolant flow distribution.

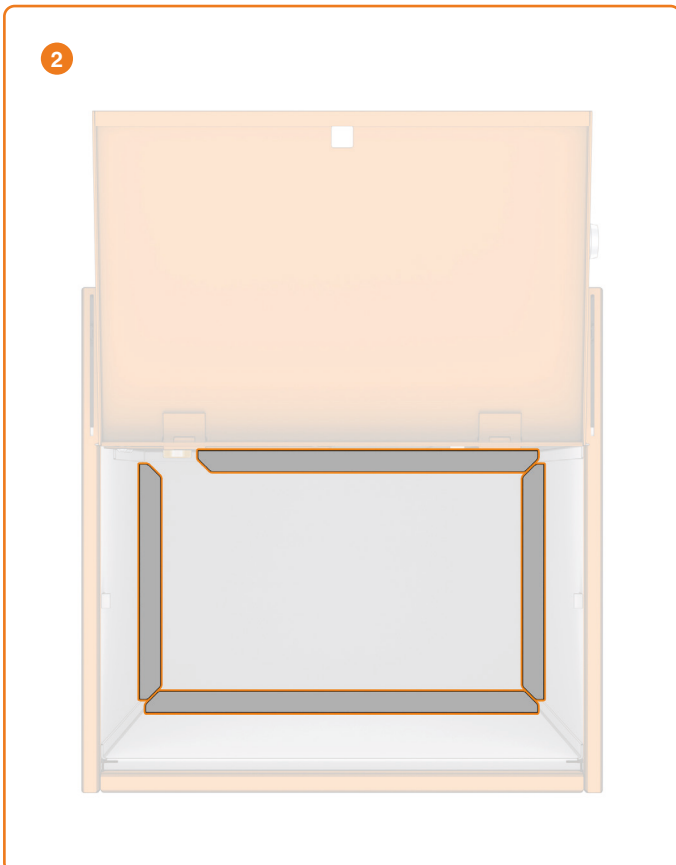

STEP 4

Connect all necessary cables to the miners. Ensure that each cable is firmly and securely inserted into the PSU socket. Be sure to use cables that have the appropriate thermal and power ratings for immersion-cooled environments. Next, connect the Ethernet cable to the network port of each miner.

Make sure that the cables are routed without sharp bends and do not obstruct the flow of dielectric fluid. Finally, double-check all connections for stability before moving on to the filling phase.

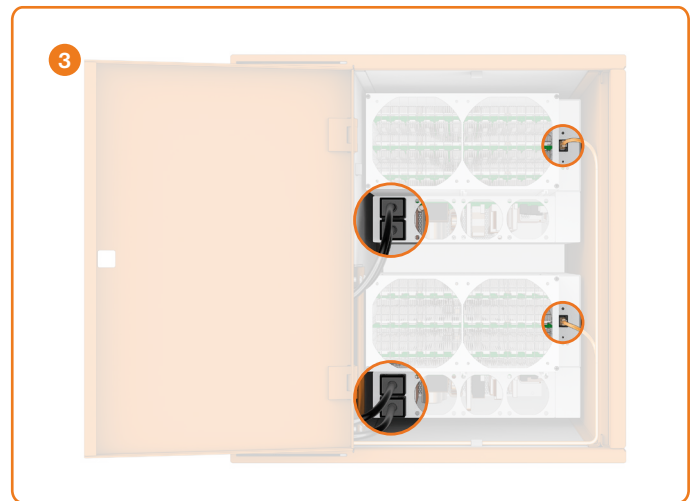
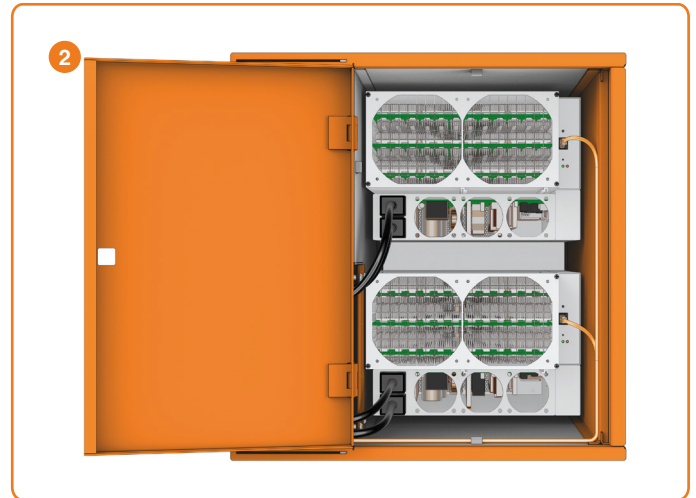
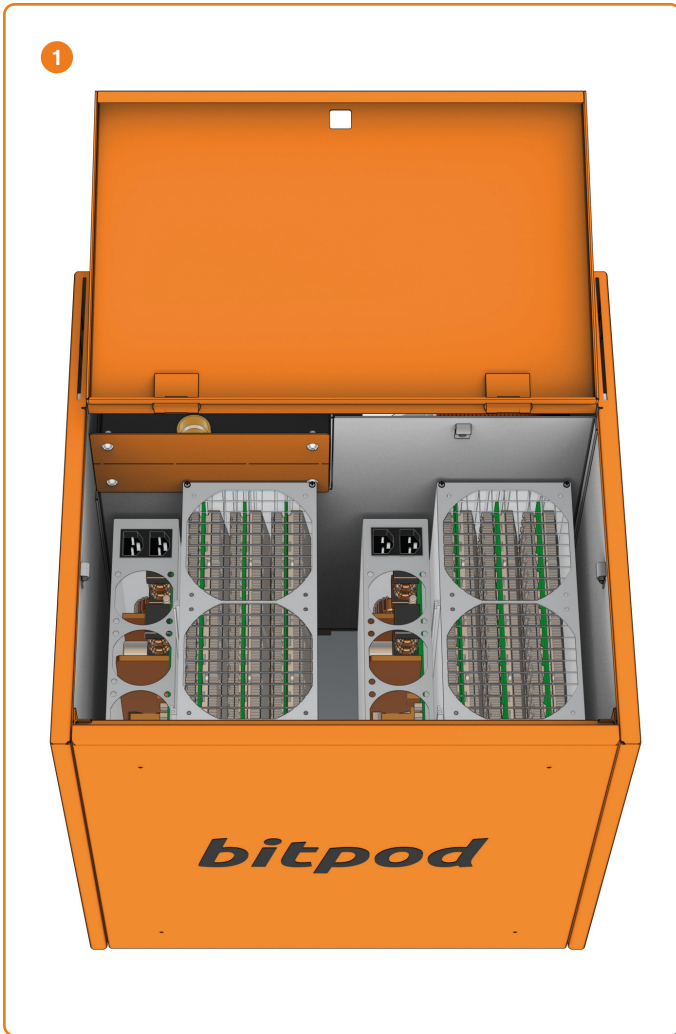

STEP 5

If the miners are positioned too low, split the divider into two parts. Then, mount the upper part of the divider at a lower position to better control the fluid level and ensure optimal fluid circulation within the cooling loop.

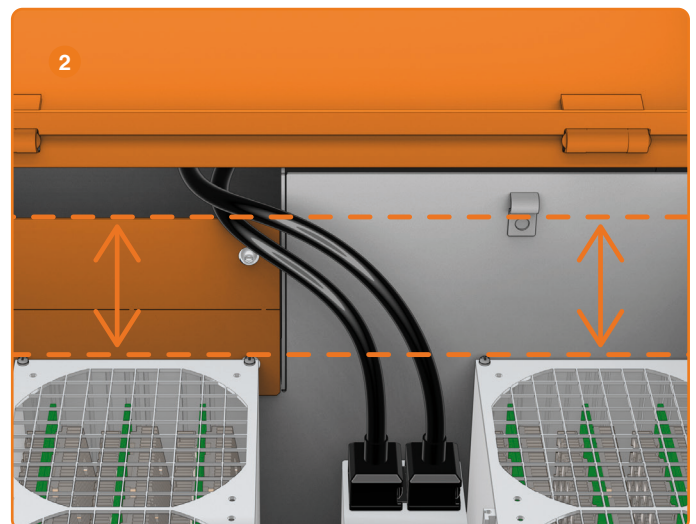
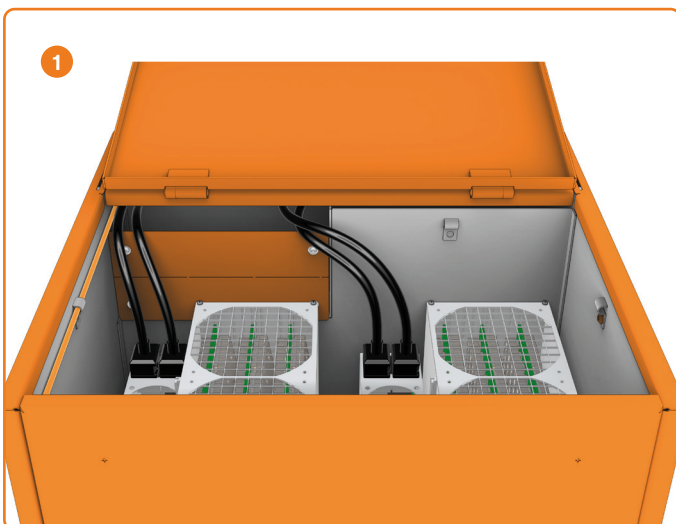

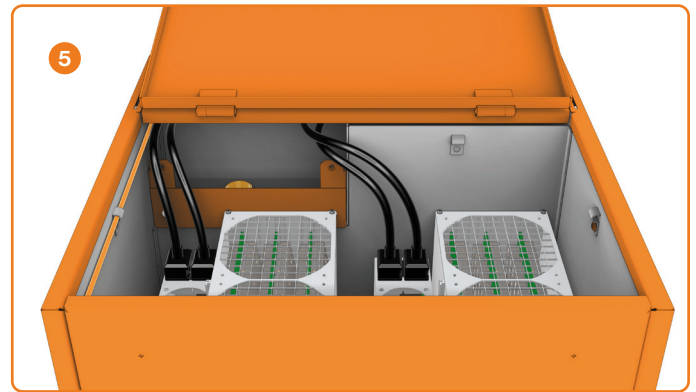
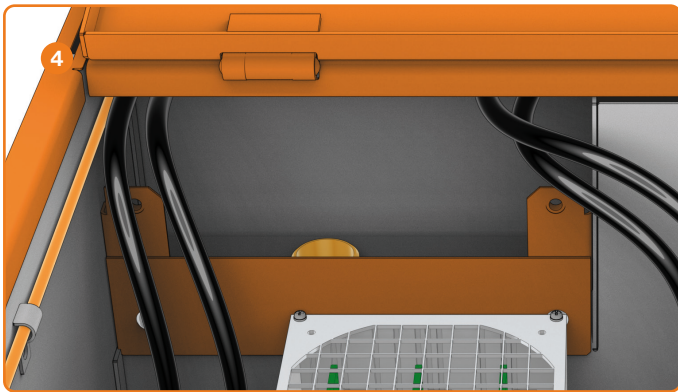
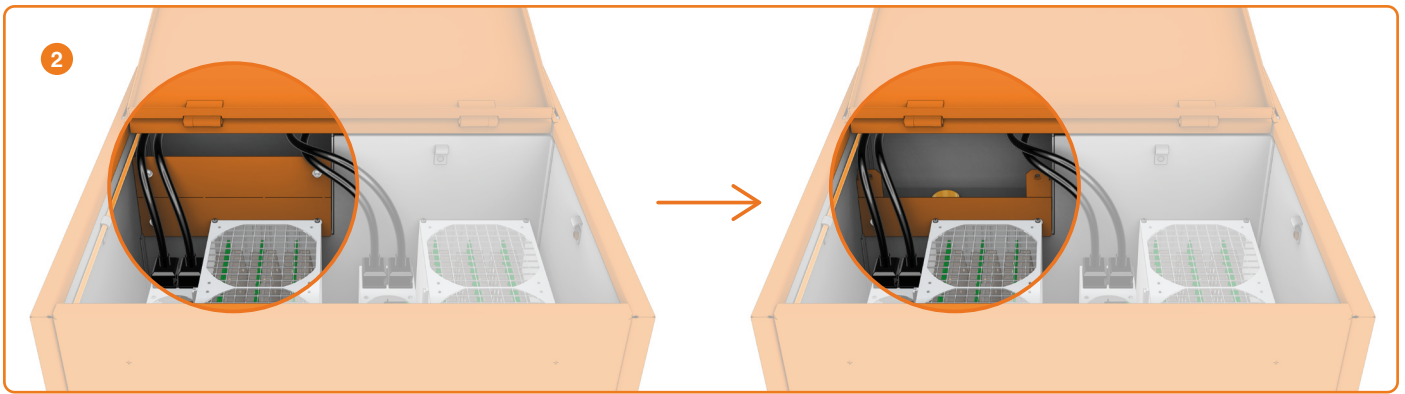

STEP 6

Open all valves in the device. Ensure all valves are in the fully open position to allow unimpeded fluid movement through the system. This step is essential to enable proper priming and continuous circulation of the dielectric fluid before powering on the cooling unit.

STEP 7

Carefully pour the dielectric fluid into the Bitpod from the ThermaSafe container until the fluid level reaches about 5 mm above the top edge of the black separator inside the housing. This separator divides the miners' chamber from the liquid return channel. Maintaining this level will create a slight overflow effect, commonly referred to as the "waterfall effect".

If you hear the pump making slurping noises, it means that air is being sucked in, which indicates that the fluid level is too low or not properly contained. In this situation, you should either add more dielectric fluid to raise the fluid level, or install the upper half of the baffle (separator extension) to stabilize the flow and prevent air intake.

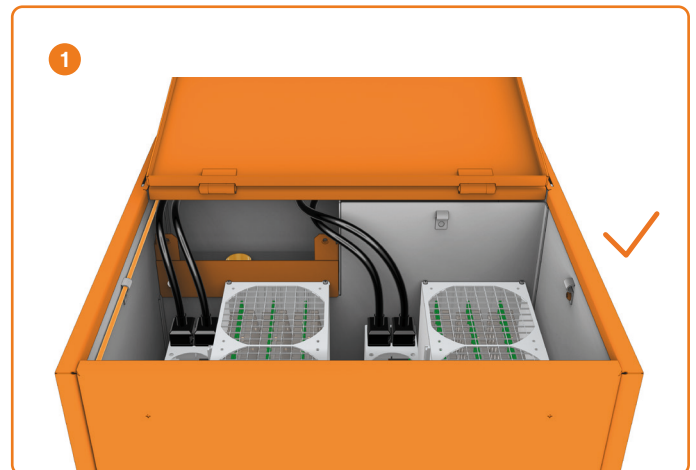

WARNING

Once the pump is turned on, the fluid level may drop slightly due to circulation. Monitor the system and add more fluid if necessary to maintain the correct level. Refer to the Troubleshooting section if you encounter symptoms of an incorrect fluid level.



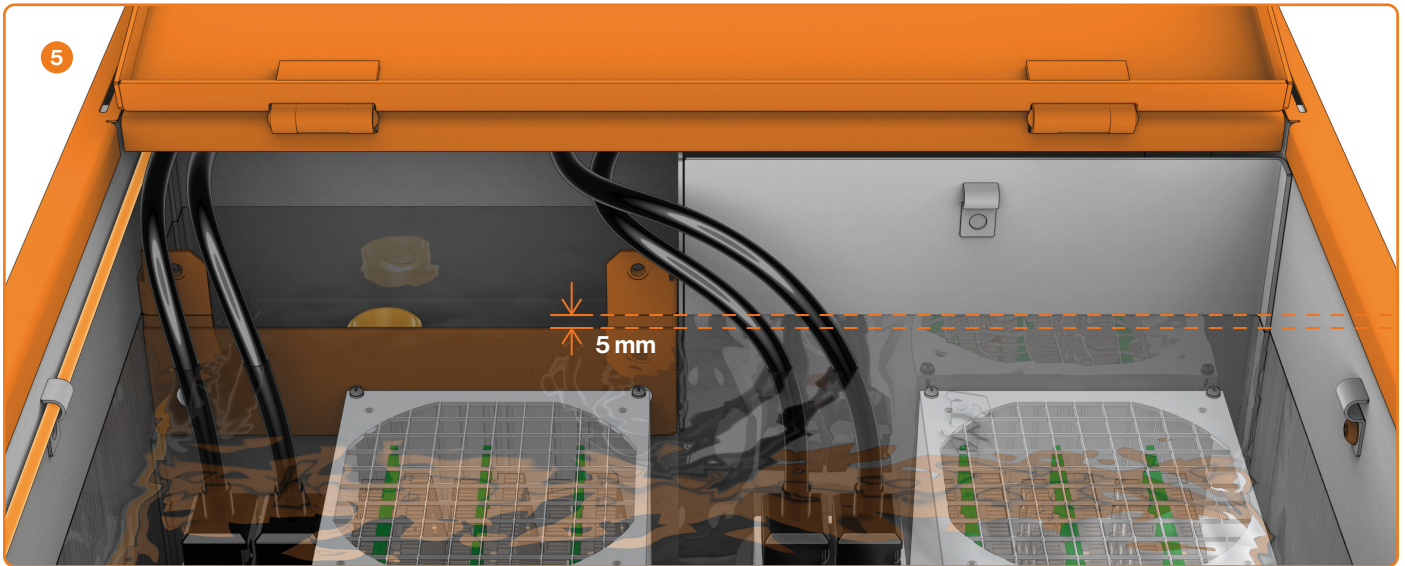
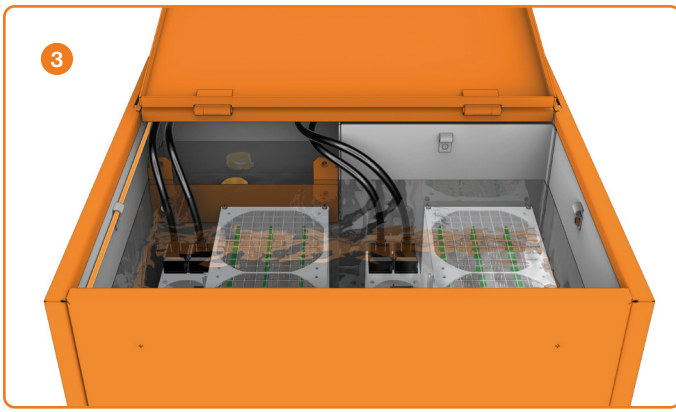

4.5. ELECTRICAL CONNECTION

1

Before connecting any components, verify that the power supply meets the system's electrical requirements. The system must be powered by a single-phase 230 V (in the range of 220–240 V) at a frequency of 50/60 Hz. Ensure that the outlet is grounded and complies with local electrical safety codes.

2

Ensure that the power source is not set up as American split-phase 240 V (which consists of 2×120 V). This configuration can lead to voltage levels of 243–244 V, potentially causing permanent damage to internal electronics like fan controllers and capacitors. Additionally, avoid connecting the system to a 208 V power supply.

3

When operating in a region with 110–120 V AC power (such as North America), you should use a step-up voltage converter that outputs 230 V AC. The converter must be able to support at least twice the total wattage of all connected equipment. For a typical setup, a transformer rated for 2500 W or higher is sufficient.

4

Connect the voltage converter to the local 120 V power source. Then, connect both the Dry Cooler and the enclosure to the 230 V output of the converter. This setup protects sensitive equipment and ensures compatibility with European and Asian power standards.

5

Examine all power cables and connectors for signs of wear, damage, or defects. Use only power cords rated for 230 V AC with appropriate current capacity. Ensure cables are not subjected to mechanical stress, stretching, or pinching.

6

Connect the enclosure and Dry Cooler to the verified power supply. If any plug replacement is needed, consult a certified electrician.

4.6. SENSORS AND DISPLAY

STEP 1

Position the sensors in the desired locations:

- Place sensors at the bottom and top inside the Bitpod to measure dielectric fluid temperature.
- Place additional sensors on the elbows at the hoses to measure inlet and outlet water temperatures.

STEP 2

Connect the display following the provided instructions:

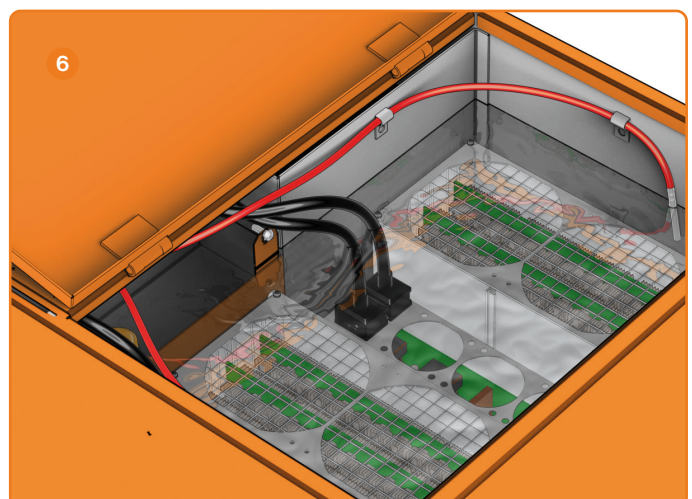
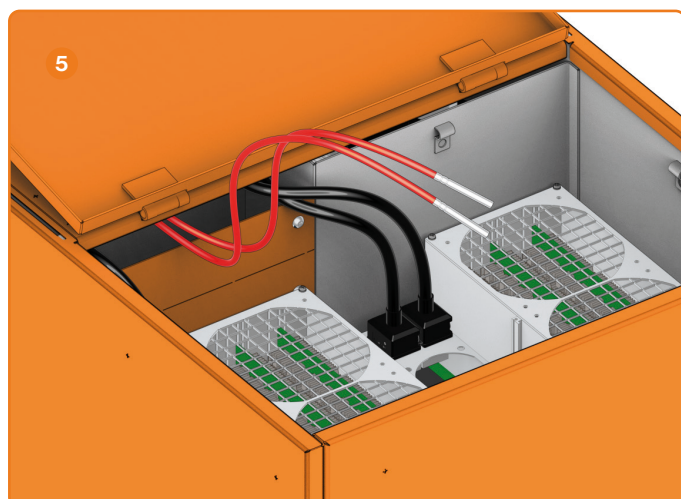
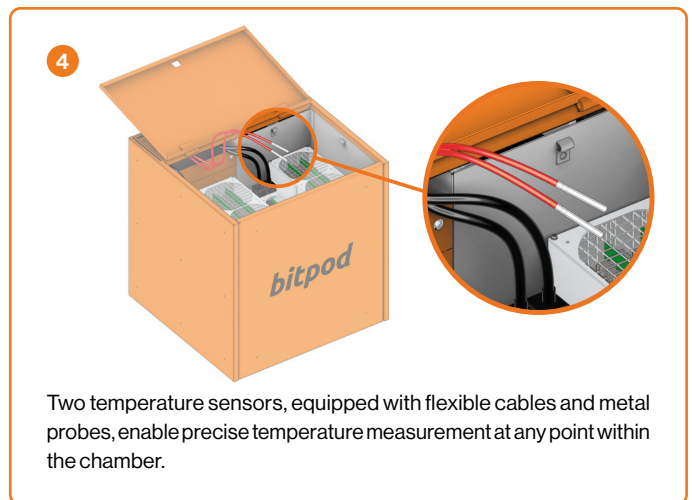
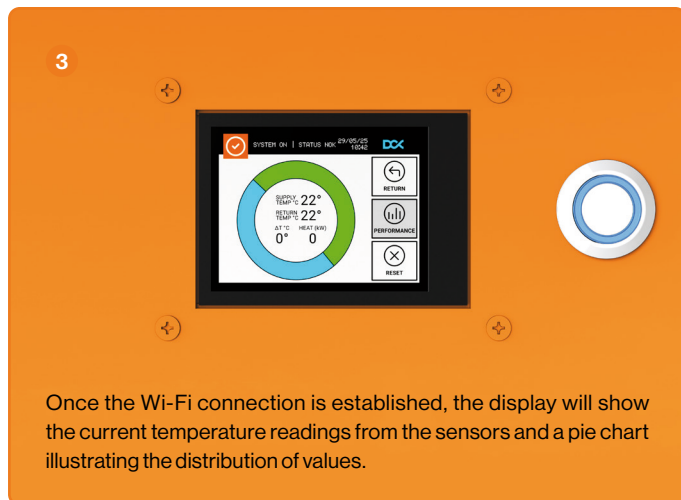
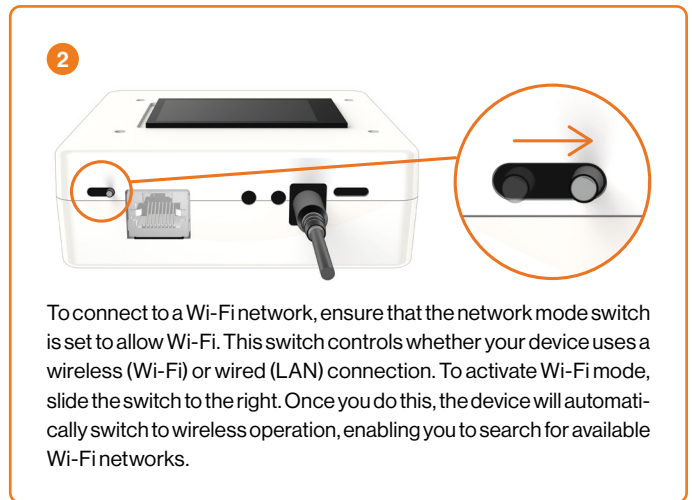
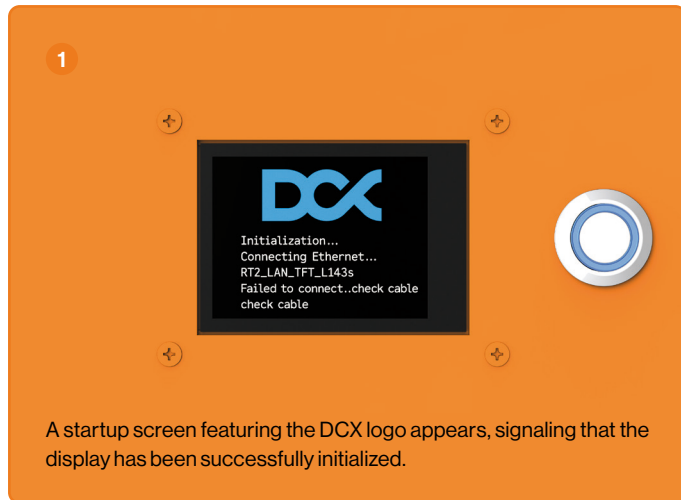

5. Operation

5.1. TURNING THE BITPOD ON AND OFF

To turn on the pump, plug it into a power socket. To turn it off, either unplug it from the socket or disconnect the power source.

5.3. BITPOD

Ensure that the enclosure cover is securely closed during operation. If necessary, verify the placement of sensors and the functionality of the screen.

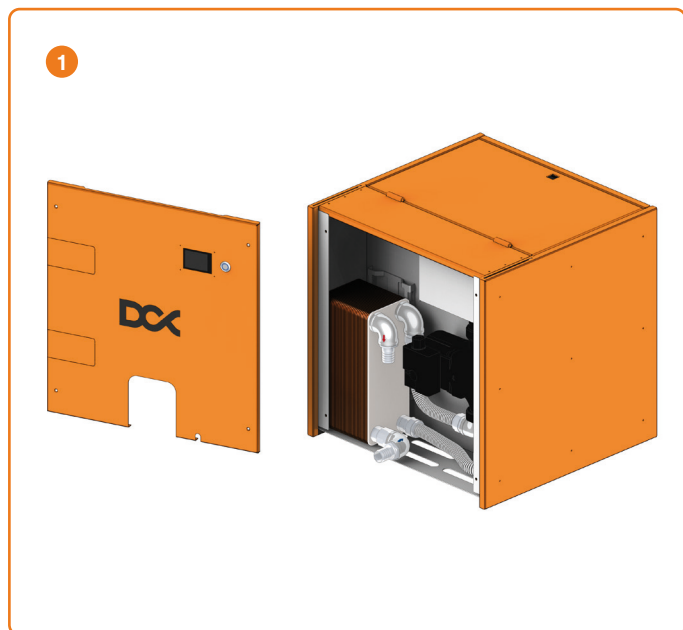

5.2. TURNING THE DRY COOLER ON AND OFF:

Connect the pump inside the Dry Cooler to a power socket. Then use the labeled fuses located under the Dry Cooler cover to power individual components:

- The “**P**” fuse switches on the **pump**.
- The “**D**” fuse switches on the **fan controller**.
- The “**F**” fuse switches on the **fans**.

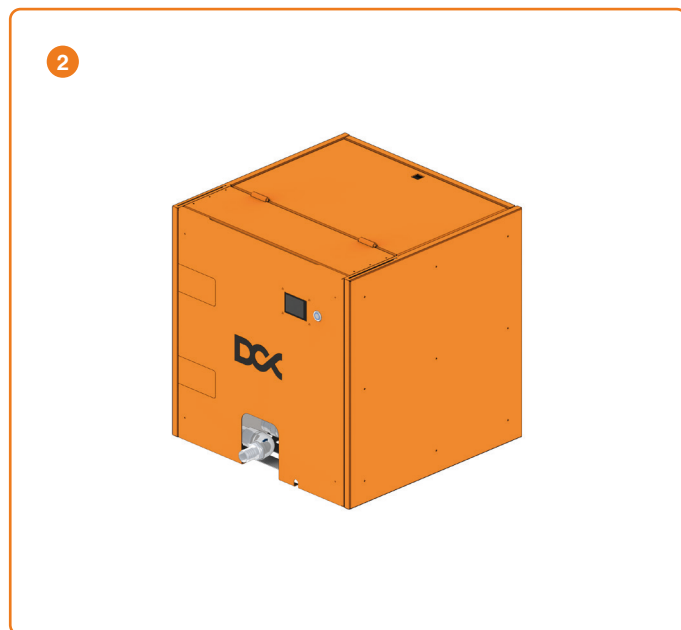

5.4. FAN CONTROLLER

The Dry Cooler’s fan cools the water and can be controlled in two ways:

DIRECT CONTROL (RECOMMENDED):

This method runs the fan at full power (100%) for maximum cooling performance.

STEP 1

Press the „D” fuse.

STEP 2

Activate the fan with the “F” fuse.

STEP 3

The fan will immediately operate at 100% speed, providing optimal cooling capacity.

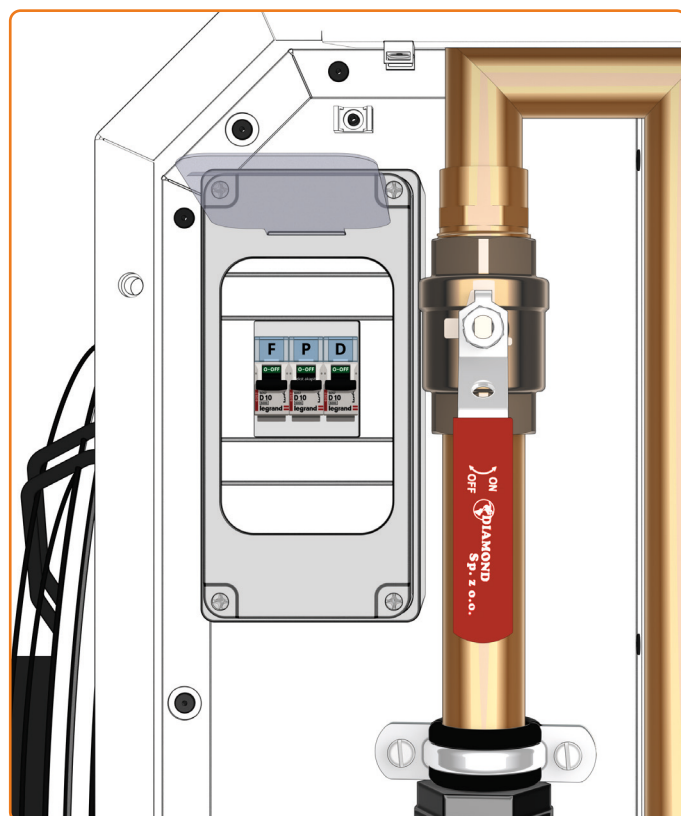

VARIABLE CONTROL:

This method enables automatic adjustment of the fan speed based on the temperature of the water.

1

Open the side cover of the Dry Cooler to access the fan controller unit (the black box).

2

Turn OFF the fan controller using the main power switch (set to "0").

3

Press and hold the "P" button.

4

While holding "P", switch the main power ON (set to "I").

5

Wait for two horizontal lines "--" to appear on the display, then release the "P" button. The "Configuration" LED and the first parameter LED will light up.

6

Use the "+" and "-" buttons to configure the following parameters. Press "P" briefly to proceed to the next step:

- Maximum Fan Speed [%]: Sets the fan's top rotational speed. Use the lowest effective setting—e.g., if the fan operates identically at 60% and 50%, set it to 50%.
- Minimum Fan Speed [%]: Sets the lowest continuous fan speed. Do not set this below 50%. Operating fans below 50% may not generate enough torque to keep them spinning reliably, leading to stalling and possible motor damage.
- Maximum Speed Activation Temperature [°C]: The temperature at which the fan reaches the maximum defined speed. The fan ramps up linearly from the switch-on temperature to this value.
- Fan Switch-On Temperature [°C]: The threshold temperature to activate the fan at minimum speed. Includes a 1°C hysteresis. For example, if set to 30°C, the fan turns ON at >30°C and OFF below 29°C.

7

To confirm your settings, press and hold the "P" button until all LEDs begin flashing. This will reboot the controller with the new configuration.

INFO

Settings can be saved at any point during configuration by holding "P".

5.5. RESET TO FACTORY SETTINGS

STEP 1

Turn OFF the regulator using the main power switch, setting it to position "0".

STEP 2

Press and hold the "+" button on the controller.

STEP 3

While continuing to hold the "+" button, turn on the controller by switching the main power switch to position "I".

STEP 4

Wait until the display shows "dE", then release the "+" button.

STEP 5

Press the "P" button briefly, just once.

STEP 6

All status LEDs will begin flashing, indicating that the controller has been successfully reset to factory default settings.

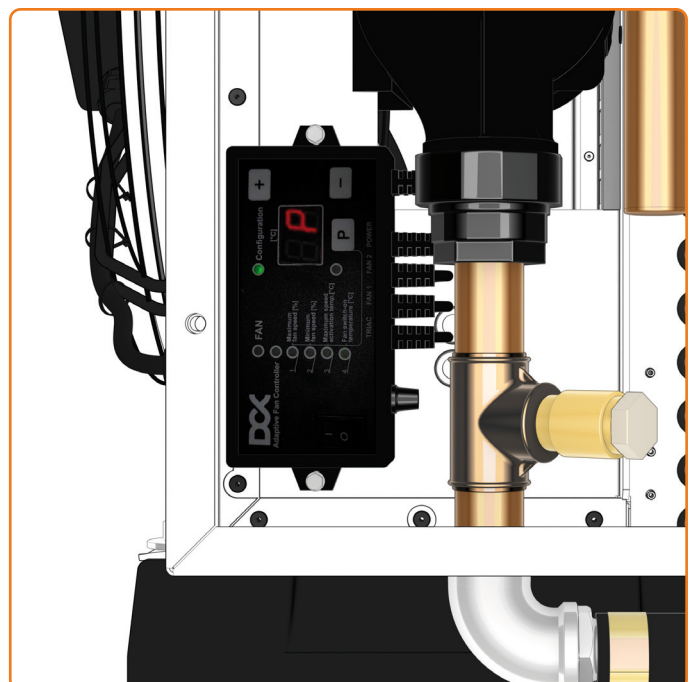

5.6. MONITORING

2



The display features a screen saver function. To reactivate the display, tap anywhere on the touchscreen surface.

3

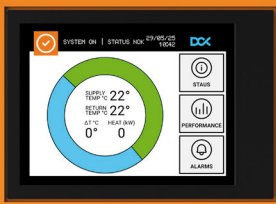

Upon reactivation, the status menu is displayed, showing current temperature readings and a pie chart.

4



To view a detailed pie chart, select **Performance** button.

5



To reset all current measurements and clear the performance chart, select the **Reset** button.

5



To return to the previous menu, select the **Return** button.

6



To access the Settings menu, tap the **DCX logo** located in the upper right corner of the screen.

7

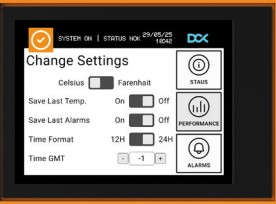

In the **Settings** menu, the following options are available: Change temperature unit, switch between Celsius and Fahrenheit, Save Last Temp, Save Last Alarm, Time Format, Time GMT

8

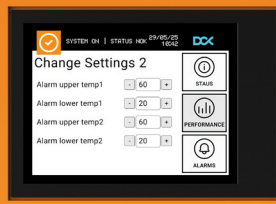

To move to the next settings tab, tap the **DCX logo** in the upper right corner again. On this page, you can set the Upper and Lower **Alarm** thresholds.

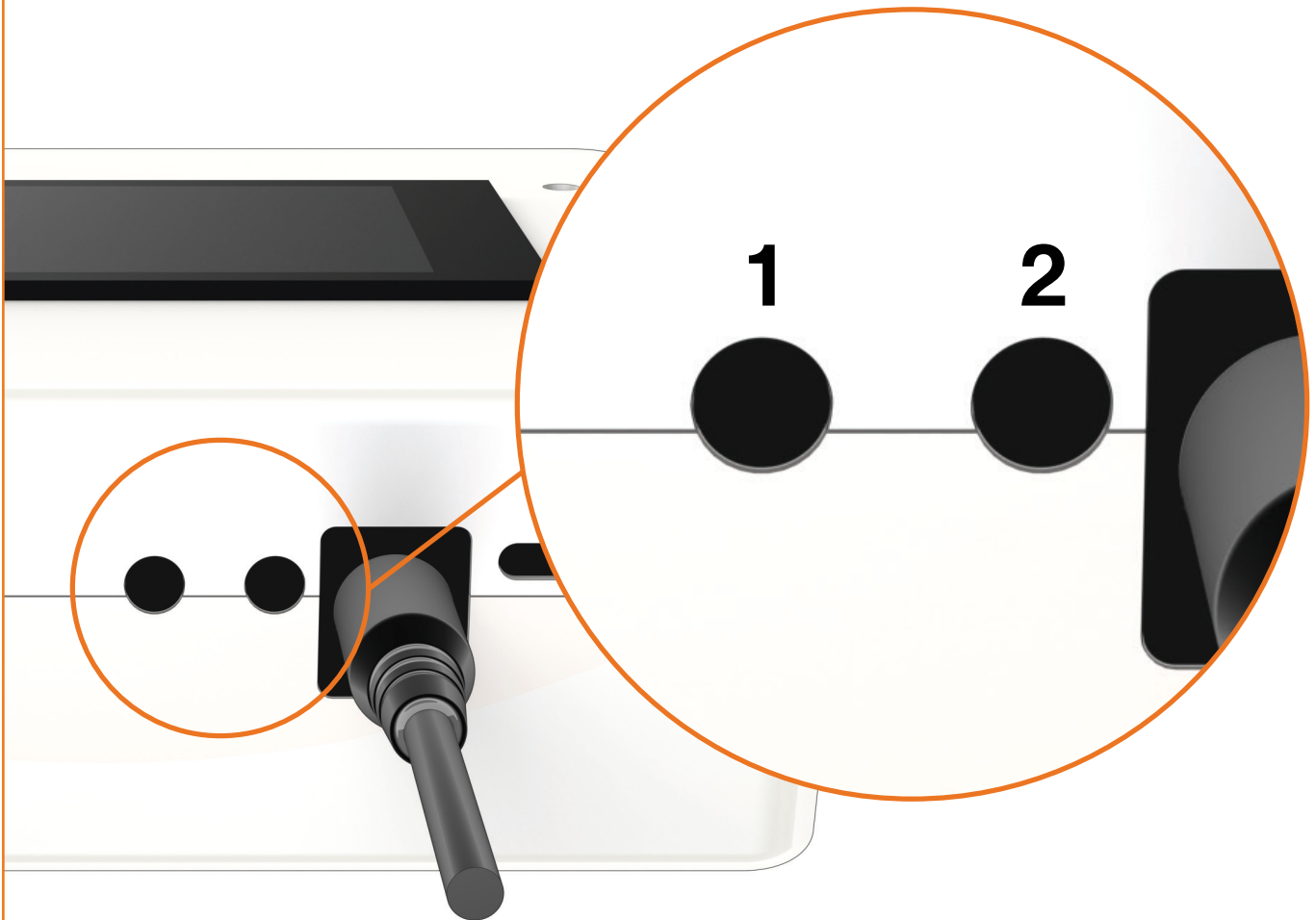

To reset the saved WiFi network settings, press the Reset button and then hold the Default button.

1. Reset button
2. Default button



DRY COOLER COVER REQUIREMENT

The Dry Cooler cover must always be kept securely closed during normal operation to protect its internal components from rain, dust, and other contaminants that could interfere with proper functioning or cause damage to electronic parts and fans. The cover may only be opened for scheduled maintenance or adjustment procedures. To do this, follow these steps:

1

Disconnect the unit from the power supply.

2

Ensure that all fans have come to a complete stop.

3

Remove the protective plugs from the cover.

4

Unscrew and remove the corner screws securing the cover.

5

Carefully lift the cover, avoiding any sudden movements that may damage wiring or internal components.

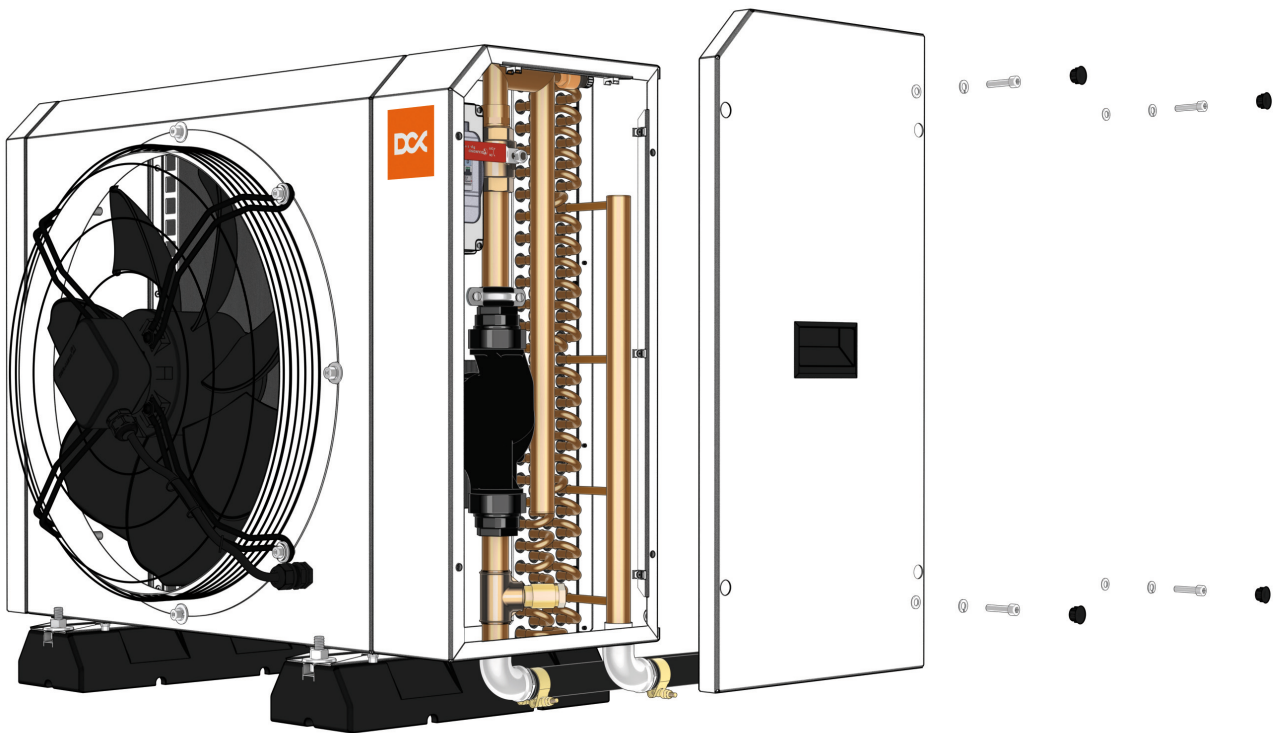

According to the manufacturer's recommendations, the unit must be operated in accordance with the installation and user manual. Any service work should only be performed after disconnecting the power supply and ensuring that the fans are not running. Operating the Dry Cooler with

an open cover increases the risk of water ingress, mechanical damage, and improper heat dissipation. Failure to comply with this requirement may void the warranty.

6. Maintenance

Regular maintenance of the immersion cooling system is crucial for optimal performance, durability, and safety. The following guidelines outline the key aspects of system upkeep and should be adhered to as part of a structured maintenance schedule.

6.1. REGULAR INSPECTIONS

- Monitor water and chip temperatures on the miners regularly.
- Verify proper operation of **temperature and flow sensors**.
- Perform a **visual inspection** of all cabling and electrical components, checking for corrosion, discoloration, or signs of overheating.

6.2. CLEANING

BITPOD

Regularly monitor the coolant system for air bubbles and remove them immediately. Air pockets can restrict fluid flow and may cause the pump to draw air instead of coolant, leading to reduced performance or damage. Always maintain the proper fluid level. Clean the heat exchanger coils every 1 to 3 months to remove leaves, dust, insects, and other debris. Use compressed air or gently rinse with water. Make sure the power is disconnected before performing any cleaning procedures.

DRY COOLER

Regularly clean the Dry Cooler of leaves, dirt, and debris to maintain optimal efficiency. Clean the fan blades and housing frequently to ensure proper airflow and to prevent premature wear. If leaves or larger debris accumulate, remove them promptly. A pressure washer may be used, but ensure that the water pressure is not too high to avoid damaging the equipment.

6.3. COOLANT MAINTENANCE

DIELECTRIC FLUID

Inspect the fluid every 1–3 months for discoloration or contamination. Under normal operating conditions, high-quality dielectric fluid typically remains effective for up to 10 years without needing replacement.

WATER-GLYCOL MIXTURE

Regularly check the coolant level and replenish as needed, following the manufacturer's recommended water-to-glycol ratio. Always verify fluid quality and top up only with the correct mixture to maintain optimal thermal performance and system longevity.

7. Troubleshooting

7.1. ERROR E1/E- ON THE DRY COOLER PUMP

This error can arise due to one of the following reasons:

- Debris, residue, or a solid object obstructing the pump propeller.
- Excessive pressure when priming the loop.
- Incomplete removal of air from the loop.

TROUBLESHOOTING STEPS

1

Check the system pressure (or recall the initial pressure used during installation).

2

Use the air release valve to check for air in the system (ensure the air release valve is positioned at the highest point in the loop for effective venting). Observe whether only water is released or if air is still present.

3

If both pressure and air removal are adequate, remove the pump and inspect for any debris or residue obstructing the propeller.

ADDITIONAL STEPS

If possible, check the voltage on the pump breaker and take a photo of the readings before dismantling the pump. Also, send pictures of your system's power setup to support.

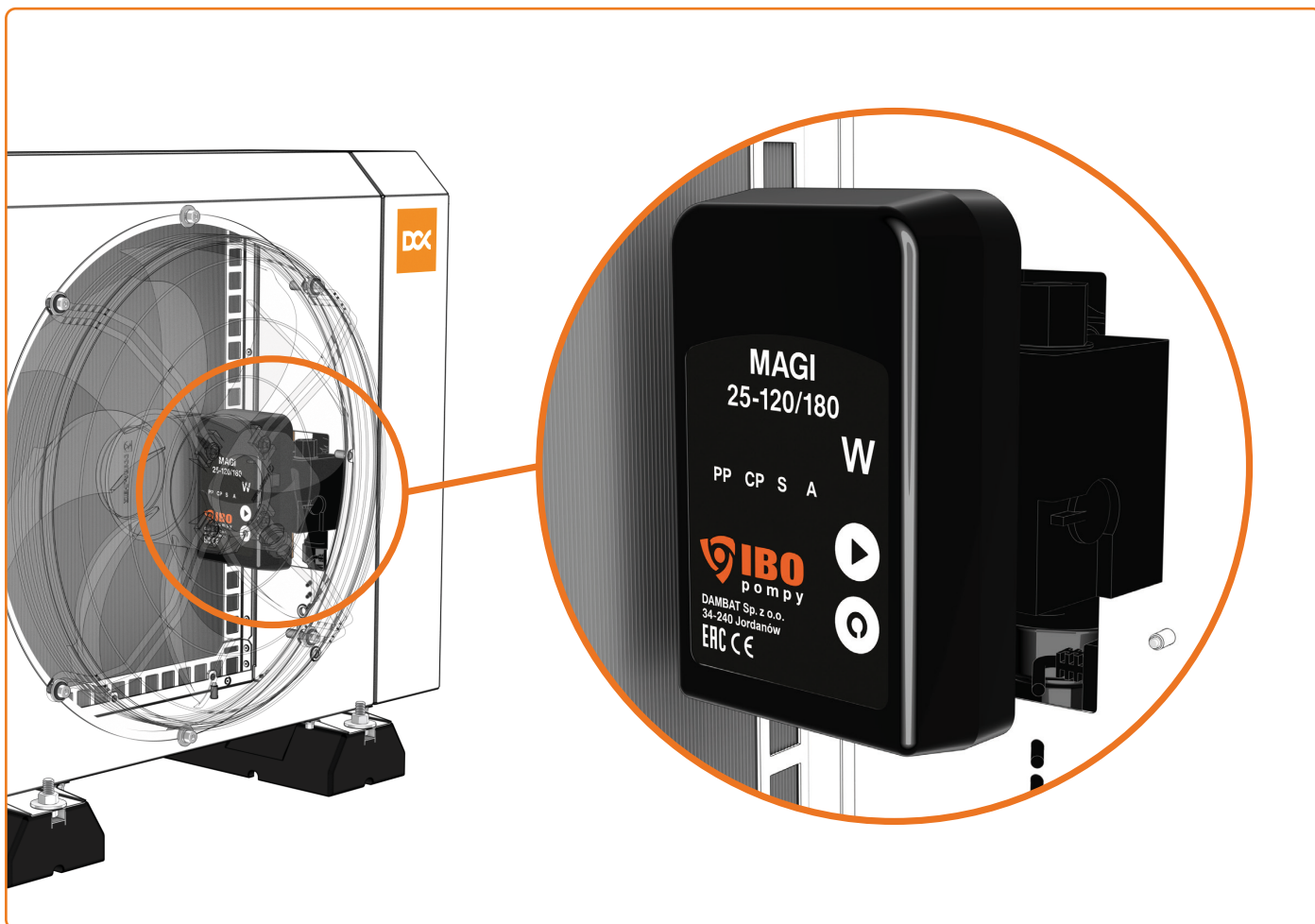

7.2. PUMP IN THE ENCLOSURE IS OVERHEATING:

Overheating may occur if the pump is sucking in air due to low levels of dielectric fluid in the enclosure. Add additional fluid until the pump operates smoothly, with no "slurping" sound indicating air intake.

8. FAQ

WHAT ARE THE PRODUCT SPECIFICATIONS/ DIMENSIONS OF YOUR ENCLOSURES/RACKS/DRY COOLERS?

Product specifications, including dimensions and weights, are available on our website cryptocooling.eu under the "Product Specifications" tab. Scroll down to find the product of interest, where you'll find descriptions and details in the horizontal tabs above it. You can also use the top navigation panel to browse.

WHERE CAN I INSTALL THE IMMERSION SYSTEM? CAN I INSTALL THE DRY COOLER INSIDE?

Dry Coolers must be installed outside the building. Ensure a minimum 30 cm gap between the back of the Dry Cooler and any wall or surface, especially if installing a 120kW unit horizontally, to allow proper air intake and output.

WHAT MATERIALS ARE USED FOR YOUR ENCLOSURES?

Our enclosures and fittings are made from steel, making them durable and resilient against high temperatures, oil, and temperature shifts, unlike plastic. They don't require special grounding and are intended as long-lasting investments.

CAN I USE DIFFERENT MINER MODELS IN THE SAME ENCLOSURE?

Yes, you can mix different ASIC miner models, but keep the enclosure filled as much as possible to maintain fluid pressure and optimize heat dissipation. Use empty fluid canisters to fill gaps if needed.

DOES IMMERSION COOLING PRODUCE A LOT OF AMBIENT HEAT? IS IT DRY OR WET HEAT?

Our systems are designed for efficient heat rejection, noise reduction, and protection against vibration, overheating, and dust. In winter, systems produce 30-50°C outlet temperatures; in summer, temperatures rise to 40-60°C. An enclosure with 8 miners can radiate up to 900W of dry heat, which is ideal for heat reuse scenarios. For maximum heat conservation, consider insulating the enclosure.

WHAT IS IMMERSION COOLING, AND HOW DOES IT WORK?

Immersion cooling cools electronic components (ASIC miners, GPUs, servers, etc.) by submerging them in non-conductive dielectric fluid, which absorbs heat far better than air. The fluid circulates through the system, transferring heat to an external Dry Cooler or heat exchanger, allowing the heat to be re-used for various applications like heating and cooling.

WHAT HARDWARE CAN BE COOLED WITH YOUR SYSTEM?

The DCX immersion system can cool a wide range of electronic hardware, including servers, GPUs, ASIC miners, switches, storage devices (SSD or helium HDDs), and more.

If you require more detailed information, we suggest visiting the DCX website at <https://dcx.eu/> or contacting DCX technical support directly.

HOW MUCH SPACE IS NEEDED FOR AN IMMERSION SYSTEM?

Our systems are compact, consisting of two main components: the immersion tank (or stacked tanks in a rack) and an optional Dry Cooler. Each immersion tank has an approximate 1-square-meter footprint. Dry Cooler sizes vary by model and heat rejection capacity. For specific dimensions and weights, visit our website under "Product Specifications."

I'M LOCATED IN THE USA WITH 110V/240V SPLIT PHASE. WILL THIS WORK?

You may need a voltage converter to adapt to EU/Asia 220-240 VAC for optimal compatibility. A 2.5-3kW voltage converter is recommended for continuous use with a single enclosure and 40kW ICP40 Dry Cooler. For suggestions, see example converters here (ensure single-phase 220-240V output).

HOW MANY MINERS CAN I IMMERSIVE IN YOUR ENCLOSURE?

Our steel immersion tanks can accommodate various types of ASIC miners and GPUs. One enclosure is suitable for approximately 2 S19j units, 4 Whatsminer units. Refer to "Product Specifications" on our website for details.

CAN I USE DIFFERENT MINER MODELS IN THE SAME ENCLOSURE?

Yes, our dual-loop systems support heat reuse through a built-in heat exchanger. They can connect to household or facility water systems for reuse in heating applications like radiators, floor heating, pools, greenhouses, and more. Here are some heat reuse applications:

- **Water Heating:** Provides 60-65°C hot water suitable for various purposes.
- **Greenhouse Conditioning:** Helps maintain ideal growing conditions, especially in cold climates.
- **Food and Beverage Production:** Heat can support aquaculture, drying, and distillation.
- **Wood Drying:** Heat can be used to dry wood efficiently, saving on energy costs.
- **Water Desalination:** Supports energy-intensive desalination processes.

WILL THE SYSTEM WORK IN HIGH-TEMPERATURE CLIMATES, LIKE THE MIDDLE EAST?

Our Dry Coolers are optimized for up to 35°C ambient temperatures. At higher temperatures, performance declines, and heat rejection becomes limited. For such climates, we recommend connecting the system to a facility water supply or chiller station, if available, to prevent overheating.



+48 601 228 528



sales@dcx.eu



support@dcx.eu



About DCX

DCX is the only European manufacturer of liquid cooling systems - an essential components of AI datacenters. We are a team of liquid cooling experts, one of leading companies in this industry (source: Data Centre Magazine "Top 10 Liquid Cooling Companies" ranking).

We offer a wide range of sustainable liquid cooling solutions, both Direct Liquid Cooling and Immersion Cooling technologies. We offer sustainable, efficient, and affordable compute for enterprise, colocation, hosting datacenters and hyperscalers worldwide. Liquid cooling systems enable sustainable heat transfer and heat reuse using warm water to cool the servers. Cooling & HVAC systems draw from 40 to 50% of total energy used in legacy data centers. Transition to Direct Liquid Cooling saves that energy, enables AI compute & replaces power hungry chillers, eliminating any water waste.

DCX designs and manufactures a comprehensive range of products, including Server Immersion Enclosures, Coolant Distribution Units (CDUs), CPU and GPU cold plates, manifolds, and other essential components of liquid cooling systems. We also provide Hydro and Immersion Containers, as well as facility-based systems. Additionally, DCX offers Immersion-optimized Dry Coolers and Thermasafe Dielectric Engineered Fluids. Our hardware solutions are complemented by data hall design and implementation services, making DCX the preferred choice for liquid cooling system solutions.

2025